

# mitsubishi

## ENGINE 4G9 SERIES

### WORKSHOP MANUAL

#### FOREWORD

This Workshop Manual contains procedures for removal, disassembly, inspection, adjustment, reassembly and installation, etc. for service mechanics. All information, illustrations and product descriptions contained in this manual are current as at the time of publication. We, however, reserve the right to make changes at any time without prior notice or obligation.

Engine .....

11A

#### FILING INSTRUCTION

Please keep these manual pages in the binder No. BN940001.

File these pages according to the signs "Added", "Revised" and "Deleted" on the "List of effective pages" which are interpreted below.

**Added:** File the pages with this label additionally in your manual.

**Revised.Deleted:** Replace the existing pages with the corresponding pages with this sign.

Missing sheets will be supplied upon request.

# INTRODUCTION

## EXPLANATION OF MANUAL CONTENTS

### Maintenance and Servicing Procedures

- (1) A diagram of the component parts is provided near the front of each section in order to give the reader a better understanding of the installed condition of component parts.
- (2) The numbers provided within the diagram indicate the sequence for maintenance and servicing procedures; the symbol  indicates a non-reusable part; the tightening torque is provided where applicable.

- **Removal steps:**  
The part designation number corresponds to the number in the illustration to indicate removal steps.
- **Disassembly steps:**  
The part designation number corresponds to the number in the illustration to indicate disassembly steps.
- **Installation steps:**  
Specified in case installation is impossible in reverse order of removal steps. Omitted if installation is possible in reverse order of removal steps.
- **Reassembly steps:**  
Specified in case reassembly is impossible in reverse order of disassembly steps. Omitted if reassembly is possible in reverse order of disassembly steps.





### Classification of Major Maintenance/Service Points

When there are major points relative to maintenance and servicing procedures (such as essential maintenance and service points, maintenance and service standard values, information regarding the use of special tools, etc.), these are arranged together as major maintenance and service points and explained in detail.

- ◀A: Indicates that there are essential points for removal or disassembly.  
▶A: Indicates that there are essential points for installation or reassembly.

### Symbols for Lubrication, Sealants and Adhesives

Information concerning the locations for lubrication and for application of sealants and adhesives is provided, by using symbols, in the diagram of component parts, or on the page following the component parts page, and explained.

-  ..... Grease (multipurpose grease unless there is a brand or type specified)
-  ..... Sealant or adhesive
-  ..... Brake fluid, automatic transmission fluid or air conditioner compressor oil
-  ..... Engine oil or gear oil

# INTRODUCTION

Indicates the group title.

Indicates the section title.

Indicates the group number.

Indicates the section number.

Indicates the page number.

6A1 ENGINE - Water Pump and Water Pipe

11A-7-1

## 7. WATER PUMP AND WATER PIPE REMOVAL AND INSTALLATION

Denotes tightening torque.

Nm Kgm ft.lbs.

Denotes non-reusable part.

This number corresponds to the number appearing in "Removal steps", "Disassembly steps", "Installation steps" or "Reassembly steps".

Operating procedures, cautions, etc. on removal, installation, disassembly and reassembly are described.

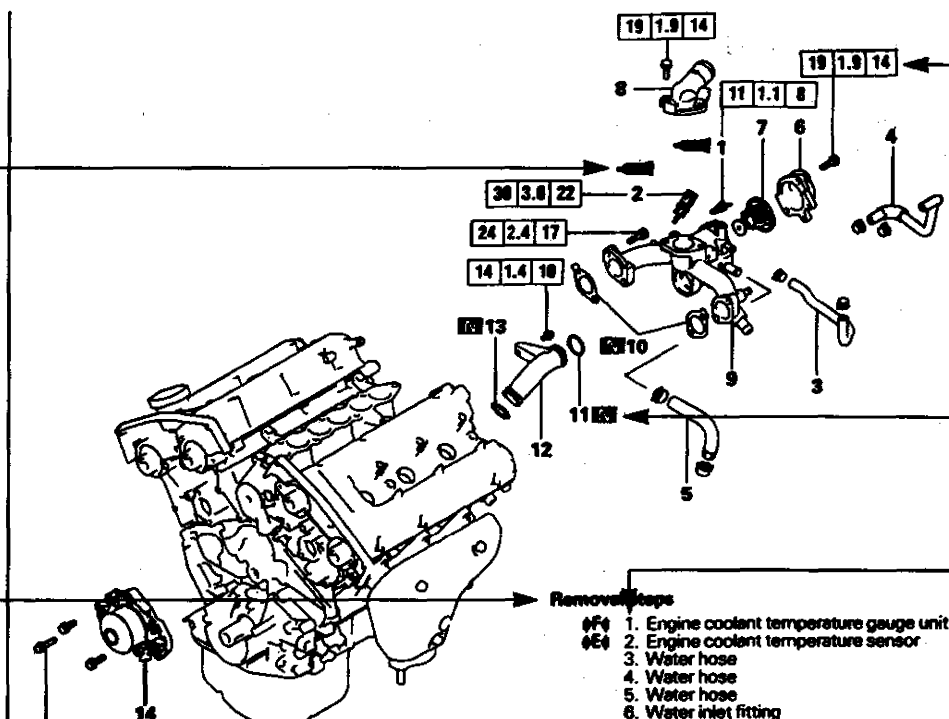

### Removal steps

- F 1. Engine coolant temperature gauge unit
- E 2. Engine coolant temperature sensor
- 3. Water hose
- 4. Water hose
- 5. Water hose
- 6. Water inlet fitting
- D 7. Thermostat
- C 8. Water outlet fitting
- 9. Thermostat housing
- 10. Gasket
- B 11. O-ring
- A 12. Water pipe
- A 13. O-ring
- A 14. Water pump

6AE0109

### INSTALLATION SERVICE POINTS

#### □A SEALANT APPLICATION TO WATER PUMP

Specified sealant:  
Mitsubishi Genuine Part No. MD970389 or equivalent

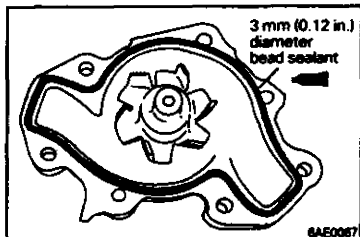

© Mitsubishi Motors Corporation Dec. 1982

PW88202

Issue date

Publication number-  
Revision code

## List of Effective Pages

Page	Revision code	Date	Remarks	Page	Revision code	Date	Remarks
11A-0-1	D	Nov. 1995		<b>11A-13-2</b>	<b>E</b>	<b>Aug. 1996</b>	<b>Revised</b>
11A-0-3 to 11A-0-8	A	Dec. 1991		11A-13-3	C	Feb. 1994	
11A-1-1	D	Nov. 1995		11A-14-1	A	Dec. 1991	
<b>11A-1-2</b>	<b>E</b>	<b>Aug. 1996</b>	<b>Revised</b>	11A-14-2	C	Feb. 1994	
11A-1-3	D	Nov. 1995		11A-14-3 and 11A-14-4	A	Dec. 1991	
<b>11A-1-4</b>	<b>E</b>	<b>Aug. 1996</b>	<b>Revised</b>	11A-15-1 to 11A-15-8	D	Nov. 1995	
11A-1-5 to 11A-1-10	D	Nov. 1995		11A-16-1	A	Dec. 1991	
11A-1-11 and 11A-1-12	C	Feb. 1994		11A-16-2 to 11A-16-5	D	Nov. 1995	
11A-2-1 and 11A-2-2	A	Dec. 1991		11A-17-1	C	Feb. 1994	
11A-2-3	D	Nov. 1995		11A-17-2	D	Nov. 1995	
11A-3-1 to 11A-3-3	D	Nov. 1995		11A-17-3	A	Dec. 1991	
11A-4-1	D	Nov. 1995		11A-17-4	C	Feb. 1994	
11A-5-1 to 11A-5-7	D	Nov. 1995		11A-18-1	C	Feb. 1994	
11A-6-1 to 11A-6-6	D	Nov. 1995		11A-18-2	D	Nov. 1995	
11A-7-1	A	Dec. 1991		11A-18-3	C	Feb. 1994	
11A-7-2 to 11A-7-4	D	Nov. 1995		11A-18-4	A	Dec. 1991	
11A-8-1	C	Feb. 1994		11A-18-5 and 11A-18-6	B	July 1993	
11A-8-2	A	Dec. 1991		11A-18-7	D	Nov. 1995	
11A-9-1	A	Dec. 1991		11A-19-1	A	Dec. 1991	
11A-9-2 to 11A-9-4	D	Nov. 1995		11A-19-2	B	July 1993	
11A-10-1 and 11A-10-2	A	Dec. 1991		11A-19-3	C	Feb. 1994	
11A-11-1 to 11A-11-5	D	Nov. 1995		11A-19-4	B	July 1993	
11A-12-1 to 11A-12-4	C	Feb. 1994		11A-19-5	D	Nov. 1995	
11A-13-1	D	Nov. 1995		11A-19-6	C	Feb. 1994	

Missing sheets will be supplied upon request.

PWEE9101-E

# ENGINE

---

# 4G9 SERIES

## CONTENTS

<b>GENERAL INFORMATION</b> .....	<b>11A- 0-3</b>
<b>1. SPECIFICATIONS</b> .....	<b>11A- 1-1</b>
<b>GENERAL SPECIFICATIONS</b> .....	<b>11A- 1-1</b>
<b>SERVICE SPECIFICATIONS</b> .....	<b>11A- 1-3</b>
<b>TORQUE SPECIFICATIONS</b> .....	<b>11A- 1-8</b>
<b>SEALANT</b> .....	<b>11A- 1-11</b>
<b>2. SPECIAL TOOLS</b> .....	<b>11A- 2-1</b>
<b>3. IGNITION SYSTEM (SINGLE CAMSHAFT ENGINE)</b> .....	<b>11A- 3-1</b>
<b>4. IGNITION SYSTEM (DOUBLE CAMSHAFT ENGINE)</b> .....	<b>11A- 4-1</b>
<b>5. DRIVE BELT AND TIMING BELT (SINGLE CAMSHAFT ENGINE)</b> .....	<b>11A- 5-1</b>
<b>6. DRIVE BELT AND TIMING BELT (DOUBLE CAMSHAFT ENGINE)</b> .....	<b>11A- 6-1</b>
<b>7. FUEL AND EMISSION CONTROL SYSTEM (SINGLE CAMSHAFT ENGINE)</b> .....	<b>11A- 7-1</b>
<b>8. FUEL AND EMISSION CONTROL SYSTEM (DOUBLE CAMSHAFT ENGINE)</b> .....	<b>11A- 8-1</b>
<b>9. INTAKE MANIFOLD AND WATER PUMP (SINGLE CAMSHAFT ENGINE)</b> .....	<b>11A- 9-1</b>
<b>10. INTAKE MANIFOLD AND WATER PUMP (DOUBLE CAMSHAFT ENGINE)</b> .....	<b>11A- 10-1</b>
<b>11. EXHAUST MANIFOLD</b> .....	<b>11A- 11-1</b>
<b>12. TURBOCHARGER</b> .....	<b>11A- 12-1</b>
<b>13. ROCKER ARMS AND CAMSHAFT (SINGLE CAMSHAT ENGINE)</b> ...	<b>11A- 13-1</b>
<b>14. ROCKER ARMS AND CAMSHAFT (DOUBLE CAMSHAT ENGINE)</b> ...	<b>11A- 14-1</b>
<b>15. CYLINDER HEAD AND VALVES (SINGLE CAMSHAFT ENGINE)</b> .....	<b>11A- 15-1</b>
<b>16. CYLINDER HEAD AND VALVES (DOUBLE CAMSHAFT ENGINE)</b> ...	<b>11A- 16-1</b>
<b>17. FRONT CASE AND OIL PUMP</b> .....	<b>11A- 17-1</b>
<b>18. PISTON AND CONNECTING ROD</b> .....	<b>11A- 18-1</b>
<b>19. CRANKSHAFT, CYLINDER BLOCK, FLYWHEEL AND DRIVE PLATE</b> .....	<b>11A- 19-1</b>

**GENERAL INFORMATION**

**ENGINE SECTIONAL VIEW – SINGLE CAMSHAFT ENGINE**

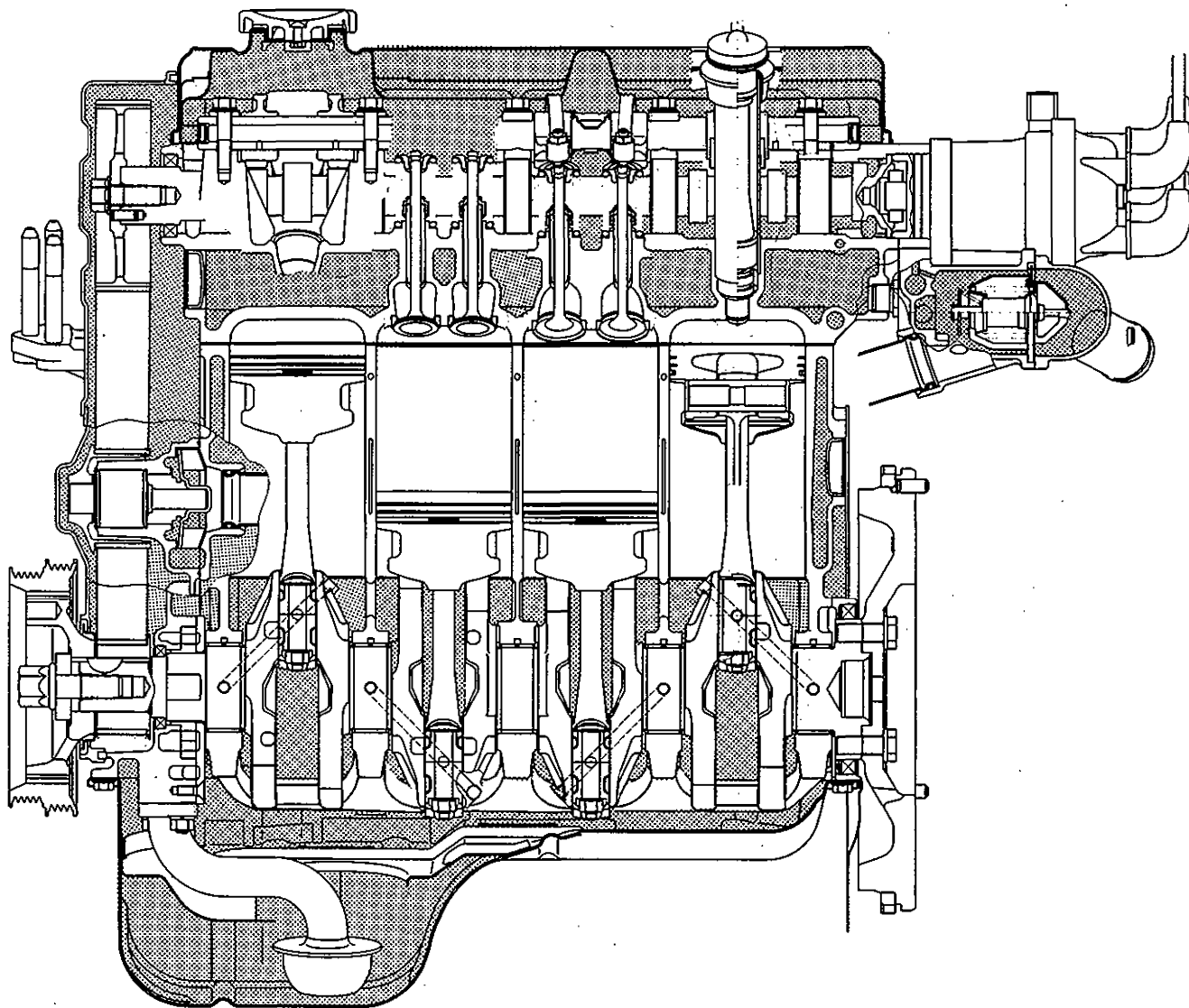

403

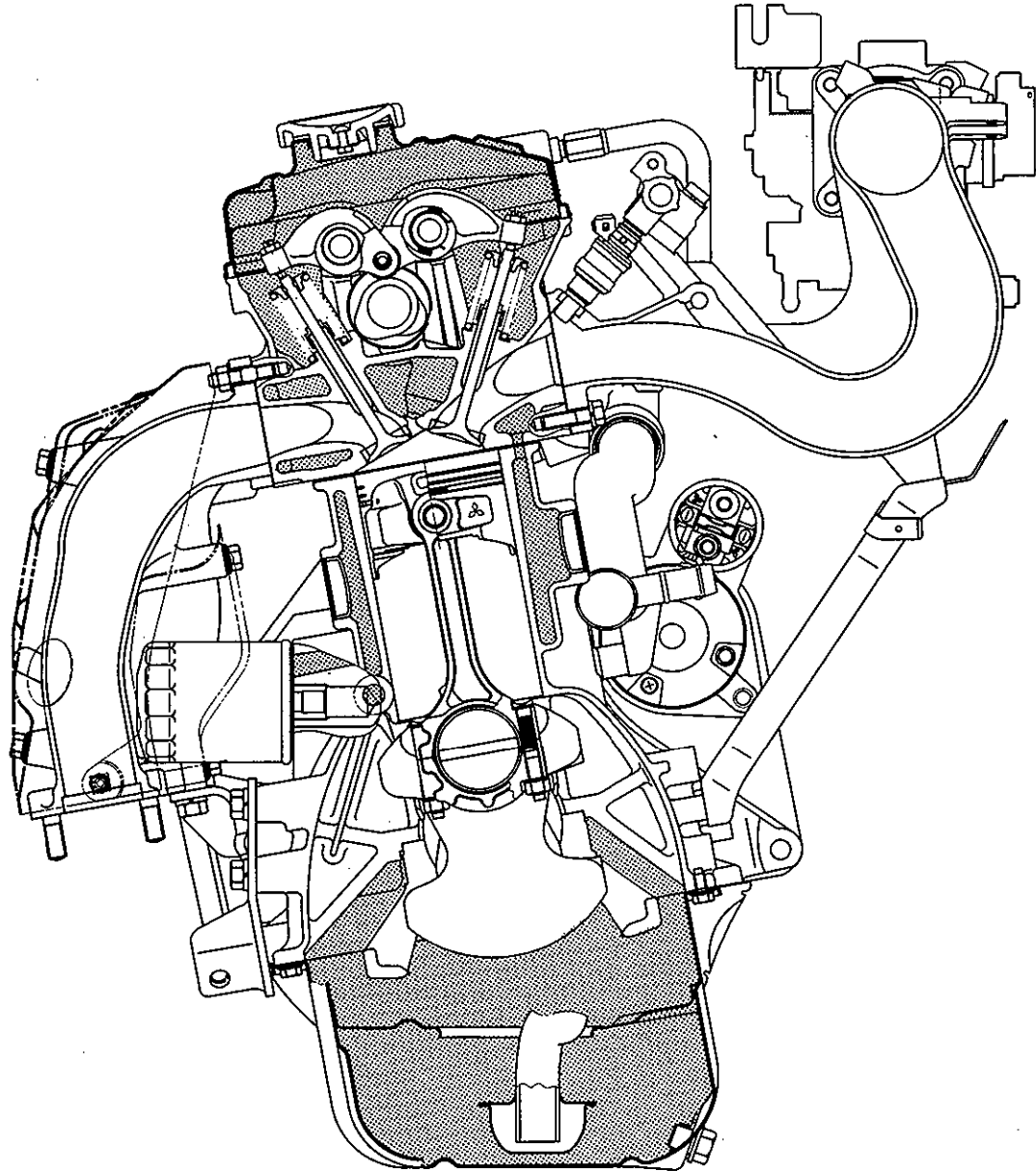

ENGINE SECTIONAL VIEW – DOUBLE CAMSHAFT ENGINE

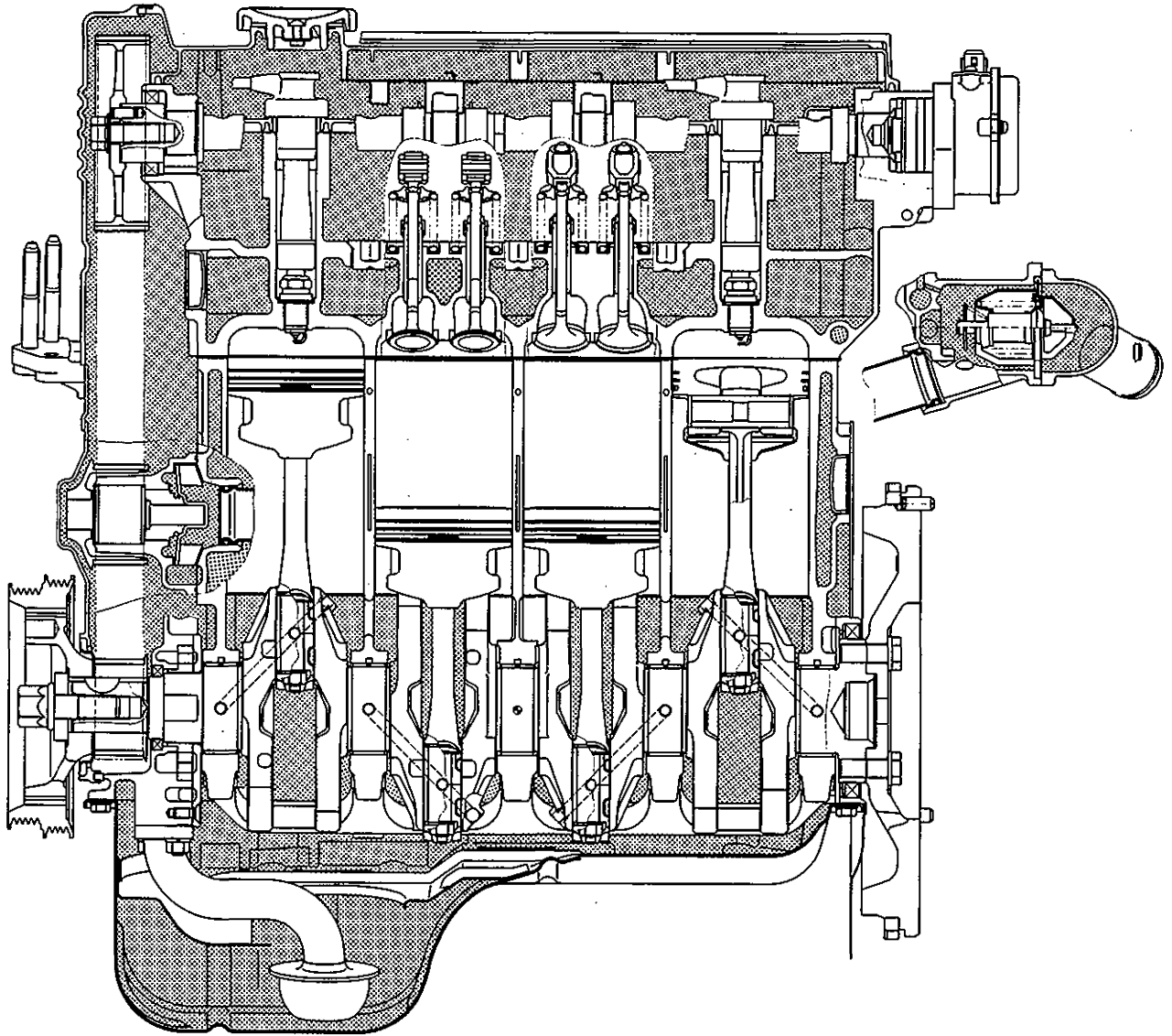

*L. H.*



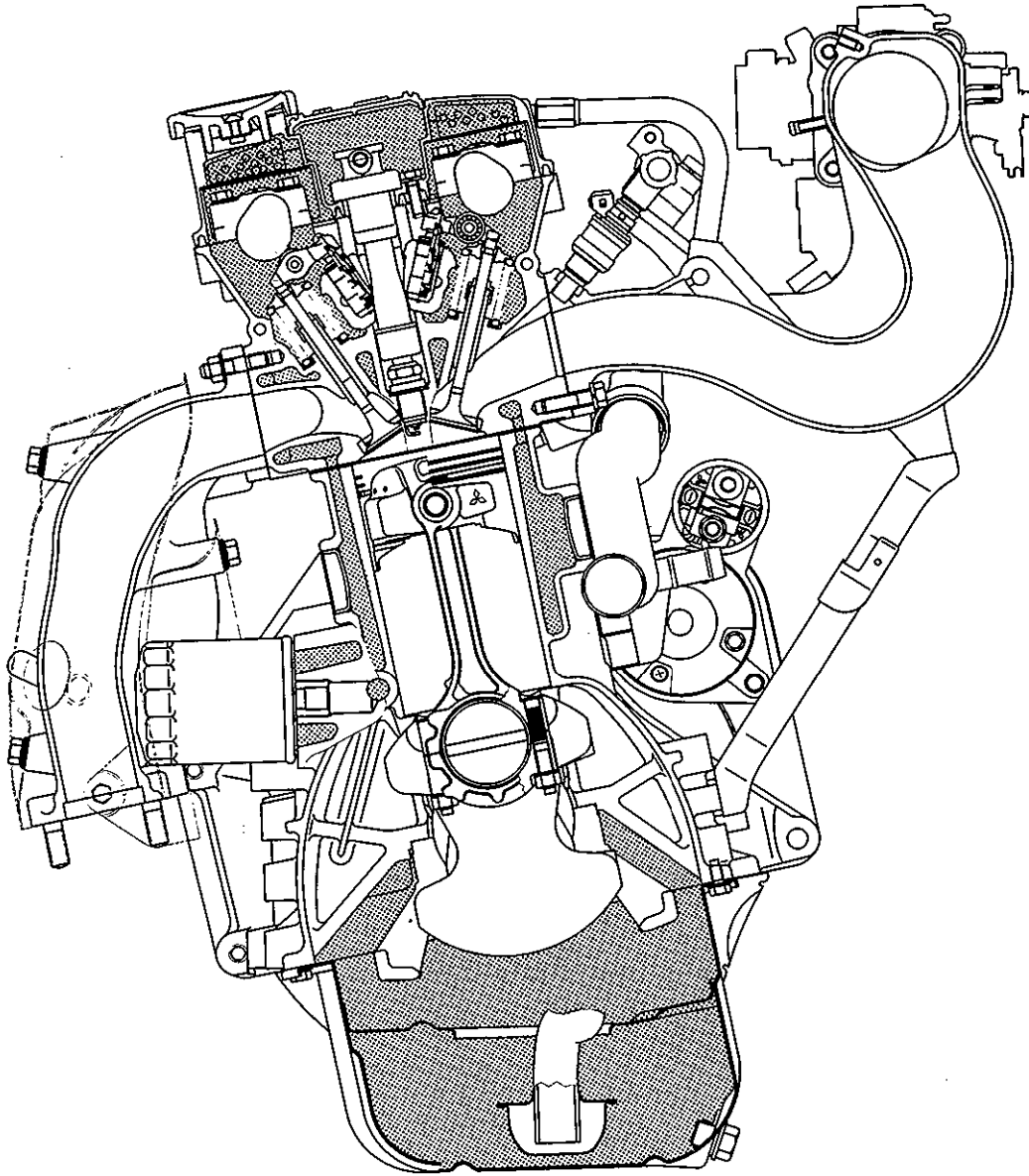

4.1

LUBRICATION SYSTEM – SINGLE CAMSHAFT ENGINE

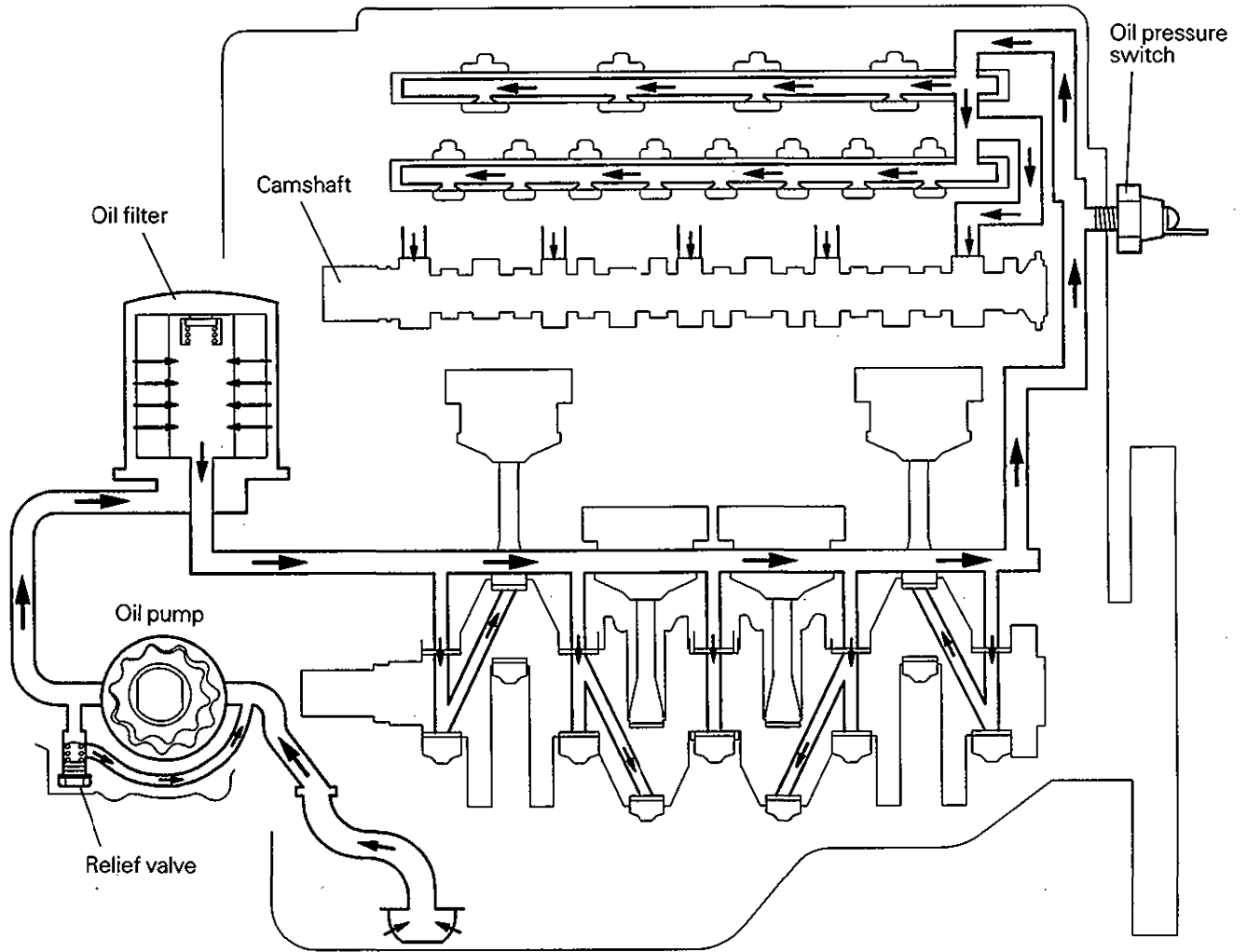

LUBRICATION SYSTEM – DOUBLE CAMSHAFT ENGINE

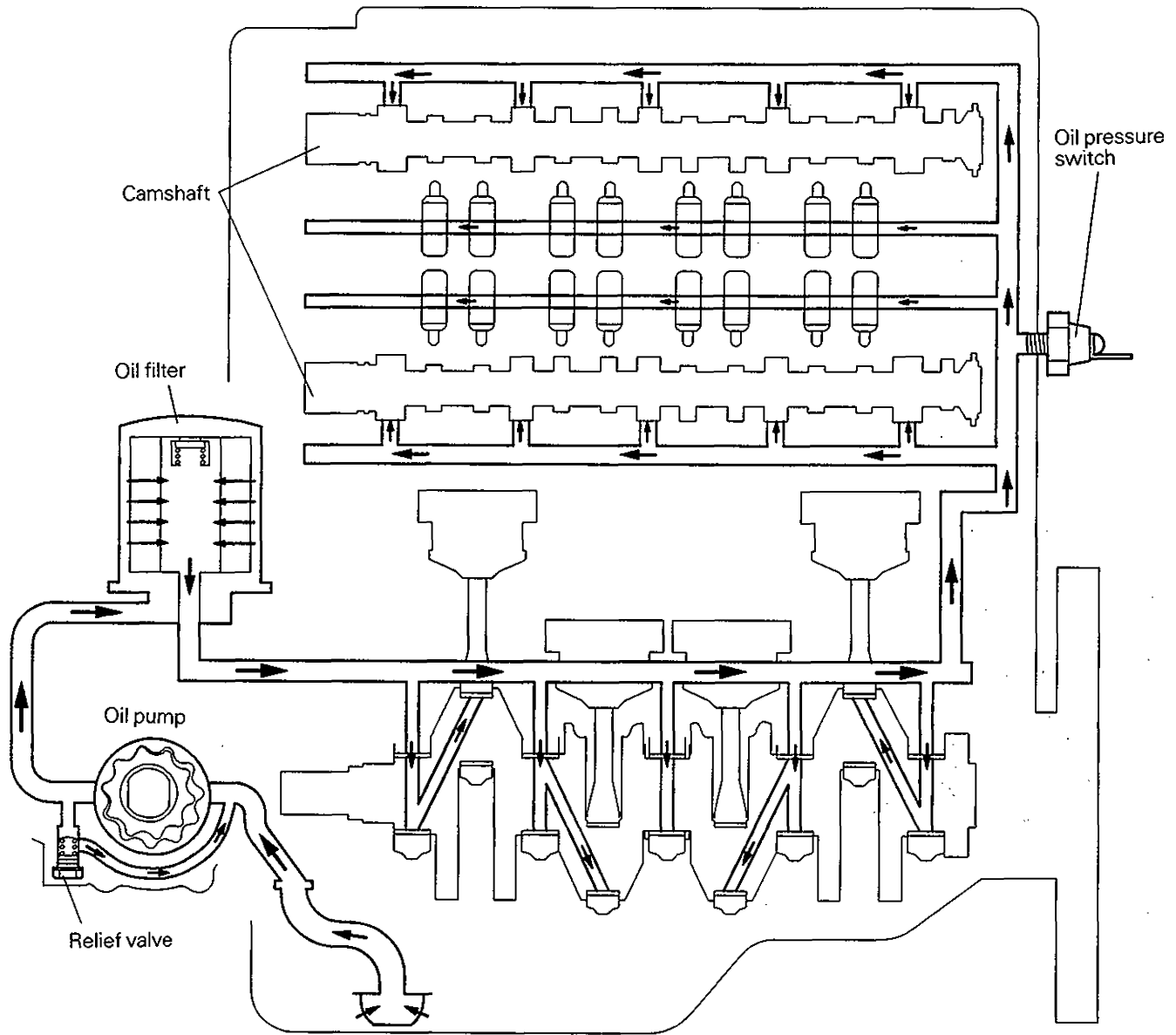

# 1. SPECIFICATIONS

## GENERAL SPECIFICATIONS

### 4G91 DOUBLE CAMSHAFT ENGINE

Description	Specifications
Type .....	In-line OHV, DOHC 4 valves
Number of cylinders .....	4
Combustion chamber .....	Pentroof type
Total displacement .....	1,496 ml (91.3 cu.in.)
Cylinder bore .....	78.4 mm (3.09 in.)
Piston stroke .....	77.5 mm (3.05 in.)
Compression ratio .....	9.5
Valve timing	
( ) : Camshaft Identification .....	(B)
Intake valve .....	Open .....
	Close .....
Exhaust valve .....	Open .....
	Close .....
Lubrication system .....	Pressure feed, full-flow filtration
Oil pump type .....	Trochoid type
Cooling system .....	Water-cooled forced circulation
Water pump type .....	Centrifugal impeller type

### 4G92 SINGLE CAMSHAFT ENGINE

Description	Specifications
Type .....	In-line OHV, SOHC 4 valves
Number of cylinders .....	4
Combustion chamber .....	Pentroof type
Total displacement .....	1,597 ml (97.4 cu.in.)
Cylinder bore .....	81 mm (3.19 in.)
Piston stroke .....	77.5 mm (3.05 in.)
Compression ratio .....	10.0 / 9.5*1
Valve timing	
( ) : Camshaft Identification	(3) (5)*1 (7)*2 (8)*3
Intake valve .....	Open .....
	Close .....
Exhaust valve .....	Open .....
	Close .....
Lubrication system .....	Pressure feed, full-flow filtration
Oil pump type .....	Trochoid type
Cooling system .....	Water-cooled forced circulation
Water pump type .....	Centrifugal impeller type

**NOTE:**

\*1: For Australia and Venezuela

\*2: MVV engine

\*3: For rear wheel drive vehicle

**4G93 SINGLE CAMSHAFT ENGINE**

Description	Specifications
Type .....	In-line OHV, SOHC 4 valves
Number of cylinders .....	4
Combustion chamber .....	Pentroof type
Total displacement .....	1,834 ml (111.9 cu.in.)
Cylinder bore .....	81 mm (3.19 in.)
Piston stroke .....	89 mm (3.50 in.)
Compression ratio .....	9.5 / 10.0*1
Valve timing	
( ) : Camshaft Identification	(1) (2)*2 (4)*3 (10)*4
Intake valve .....	Open ..... 18° 11° 16° 14°
	Close ..... 50° 61° 46° 50°
Exhaust valve .....	Open ..... 58° 55° 54° 58°
	Close ..... 10° 17° 6° 10°
Lubrication system .....	Pressure feed, full-flow filtration
Oil pump type .....	Trochoid type
Cooling system .....	Water-cooled forced circulation
Water pump type .....	Centrifugal impeller type

## NOTE

\*1: For Europe, HongKong

\*2: For Europe (up to '96 models), HongKong

\*3: Carburetor-engine

\*4: For Europe (from '97 models), Australia

**4G93 DOUBLE CAMSHAFT ENGINE**

Description	Specifications
Type .....	In-line OHV, DOHC 4 valves
Number of cylinders .....	4
Combustion chamber .....	Pentroof type
Total displacement .....	1,834 ml (111.9 cu.in.)
Cylinder bore .....	81 mm (3.19 in.)
Piston stroke .....	89 mm (3.50 in.)
Compression ratio .....	10.5 / 8.5*
Valve timing	
( ) : Camshaft Identification	(E) (D)*
Intake valve .....	Open ..... 20° 19°
	Close ..... 60° 53°
Exhaust valve .....	Open ..... 60° 63°
	Close ..... 16° 13°
Lubrication system .....	Pressure feed, full-flow filtration
Oil pump type .....	Trochoid type
Cooling system .....	Water-cooled forced circulation
Water pump type .....	Centrifugal impeller type
Turbocharger* .....	Water-cooled

## NOTE

\*: Turbocharged engine

**SERVICE SPECIFICATIONS**

mm (in.)

	Standard	Limit
<b>Auto-tensioner – Double camshaft engine</b>		
Auto-tensioner rod protrusion amount (when checked as installed on engine)	11	
Auto-tensioner rod stroke	Within 1	
Auto-tensioner rod protrusion amount (when removed from engine)	3.8 – 4.5	
<b>Cylinder head – Single camshaft engine</b>		
Flatness of gasket surface	0.03 (0.0012)	0.2 (0.008)
Grinding limit of gasket surface		*0.2 (0.008)
*Includes grinding of cylinder block.		
Overall height	119.9 – 120.1 (4.720 – 4.728)	
Oversize rework dimensions of valve guide hole (both intake and exhaust)		
0.05 (0.002) O.S.	11.05 – 11.07 (0.4350 – 0.4358)	
0.25 (0.010) O.S.	11.25 – 11.27 (0.4429 – 0.4437)	
0.50 (0.020) O.S.	11.50 – 11.52 (0.4528 – 0.4535)	
Oversize rework dimensions of valve seat ring hole		
Intake 0.3 (0.012) O.S.	31.80 – 31.83 (1.2520 – 1.2531)	
0.6 (0.024) O.S.	32.10 – 32.13 (1.2638 – 1.2650)	
Exhaust 0.3 (0.012) O.S.	29.30 – 29.32 (1.1535 – 1.1543)	
0.6 (0.024) O.S.	29.60 – 29.62 (1.1654 – 1.1661)	
<b>Cylinder head – Double camshaft engine</b>		
Flatness of gasket surface	0.03 (0.0012)	0.2 (0.008)
Grinding limit of gasket surface		*0.2 (0.008)
*Includes grinding of cylinder block.		
Overall height	131.9 – 132.1 (5.193 – 5.201)	
Oversize rework dimensions of valve guide hole (both intake and exhaust)		
0.05 (0.002) O.S.	11.05 – 11.07 (0.4350 – 0.4358)	
0.25 (0.010) O.S.	11.25 – 11.27 (0.4429 – 0.4437)	
0.50 (0.020) O.S.	11.50 – 11.52 (0.4528 – 0.4535)	
Oversize rework dimensions of valve seat ring hole		
Intake 0.3 (0.012) O.S.	34.30 – 34.33 (1.3504 – 1.3516)	
0.6 (0.024) O.S.	34.60 – 34.63 (1.3622 – 1.3634)	
Exhaust 0.3 (0.012) O.S.	30.80 – 30.83 (1.2126 – 1.2138)	
0.6 (0.024) O.S.	31.10 – 31.13 (1.2244 – 1.2256)	
<b>Camshaft – Single camshaft engine</b>		
Cam height		
Identification mark: 1		
Intake	37.78 (1.4874)	37.28 (1.4677)
Exhaust	38.09 (1.4996)	37.59 (1.4799)
Identification mark: 2		
Intake	37.97 (1.4949)	37.47 (1.4752)
Exhaust	38.09 (1.4996)	37.59 (1.4799)

	Standard	Limit
<b>Camshaft – Single camshaft engine</b>		
Cam height		
Identification mark: 3		
Intake	37.78 (1.4874)	37.28 (1.4677)
Exhaust	37.83 (1.4894)	37.33 (1.4697)
Identification mark: 4		
Intake	37.53 (1.4776)	37.03 (1.4579)
Exhaust	37.32 (1.4693)	36.82 (1.4496)
Identification mark: 5		
Intake	37.53 (1.4776)	37.03 (1.4579)
Exhaust	38.09 (1.4996)	37.59 (1.4799)
Identification mark: 7		
Intake	37.16 (1.4630)	36.66 (1.4433)
Exhaust	36.93 (1.4539)	36.43 (1.4342)
Identification mark: 8		
Intake	37.03 (1.4579)	36.53 (1.4382)
Exhaust	36.99 (1.4563)	36.49 (1.4399)
Identification mark: 10		
Intake	37.53 (1.4776)	37.03 (1.4579)
Exhaust	37.64 (1.4819)	37.14 (1.4622)
Journal O.D.	44.93 – 44.94 (1.7689 – 1.7693)	
Bearing oil clearance	0.05 – 0.09 (0.0020 – 0.0035)	
<b>Camshaft – Double camshaft engine</b>		
Cam height		
Identification mark: B		
Intake	35.31 (1.3902)	34.81 (1.3705)
Exhaust	35.20 (1.3858)	34.70 (1.3661)
Identification mark: D		
Intake	35.31 (1.3902)	34.81 (1.3705)
Exhaust	35.32 (1.3905)	34.82 (1.3709)
Identification mark: E		
Intake	35.60 (1.4016)	35.10 (1.3819)
Exhaust	35.49 (1.3972)	34.99 (1.3776)
Journal O.D.	25.95 – 25.97 (1.0217 – 1.0224)	
Bearing oil clearance	0.05 – 0.09 (0.0020 – 0.0035)	
<b>Rocker arm – Single camshaft engine</b>		
I.D.	20.02 – 20.04 (0.7882 – 0.7890)	
Rocker arm-to-shaft clearance	0.02 – 0.05 (0.0008 – 0.0020)	0.1 (0.004)
<b>Rocker arm shaft – Single camshaft engine</b>		
O.D.	19.99 – 20.00 (0.7870 – 0.7874)	
<b>Valve – Single camshaft engine</b>		
Valve length		
Intake	110.15 (4.3366)	109.65 (4.3169)
Exhaust	113.70 (4.4764)	113.20 (4.4567)
Stem O.D.		
Intake	5.97 – 5.98 (0.2350 – 0.2354)	
Exhaust	5.95 – 5.97 (0.2343 – 0.2350)	
Face angle	45° – 45°30'	

mm (in.)

	Standard	Limit
<b>Valve – Single camshaft engine</b>		
Thickness of valve head (margin)		
Intake .....	1.0 (0.039) .....	0.5 (0.020)
Exhaust .....	1.3 (0.051) .....	0.8 (0.031)
Valve stem-to-valve guide clearance		
Intake .....	0.02 – 0.04 (0.0008 – 0.0016) .....	0.10 (0.0039)
Exhaust .....	0.03 – 0.06 (0.0012 – 0.0024) .....	0.15 (0.0059)
Valve stem projection		
Intake .....	49.30 (1.9409) .....	49.80 (1.9606)
Exhaust .....	49.35 (1.9429) .....	49.85 (1.9626)
<b>Valve – Double camshaft engine</b>		
Valve length		
Intake .....	104.19 (4.1020) .....	103.69 (4.0823)
Exhaust .....	103.87 (4.0894) .....	103.37 (4.0697)
Stem O.D.		
Intake .....	5.97 – 5.98 (0.2350 – 0.2354)	
Exhaust .....	5.95 – 5.97 (0.2343 – 0.2350)	
Face angle .....	45° – 45°30'	
Thickness of valve head (margin)		
Intake .....	1.0 (0.039) .....	0.5 (0.020)
Exhaust .....	1.2 (0.047) .....	0.7 (0.023)
Valve stem-to-valve guide clearance		
Intake .....	0.02 – 0.04 (0.0008 – 0.0016) .....	0.10 (0.0039)
Exhaust .....	0.03 – 0.06 (0.0012 – 0.0024) .....	0.15 (0.0059)
Valve stem projection		
Intake .....	46.70 (1.8386) .....	47.20 (1.8583)
Exhaust .....	46.65 (1.8366) .....	47.15 (1.8563)
<b>Valve spring – Single camshaft engine</b>		
Free height .....	50.9 (2.004) .....	49.9 (1.965)
Load/installed height N (kg, lbs.)/mm (in.) .....	220 (22.0, 49)/44.2 (1.74)	
Out of squareness .....	Less than 2° .....	4°
<b>Valve spring – Double camshaft engine</b>		
Free height		
4G91 .....	44.4 (1.748) .....	43.4 (1.709)
4G93 .....	45.0 (1.772) .....	44.0 (1.732)
Load/installed height N (kg, lbs.)/mm (in.)		
4G91 .....	195 (19.5, 43)/37.5 (1.48)	
4G93 .....	262 (26.2, 58)/37.5 (1.48)	
Out of squareness .....	Less than 2° .....	4°
<b>Valve guide</b>		
Length		
Intake .....	45.5 (1.791)	
Exhaust .....	50.5 (1.988)	
I.D. ....	6.00 – 6.01 (0.2362 – 0.2366)	
O.D. ....	11.055 – 11.065 (0.4350 – 0.4356)	
Service size .....	0.05 (0.002), 0.25 (0.01), 0.50 (0.02) oversize	
Press-in temperature .....	Room temperature	



	Standard	Limit
<b>Valve seat</b>		
Seat angle .....	43°30' – 44°	
Valve contact width .....	0.9 – 1.3 (0.035 – 0.051)	
Sinkage .....		0.2 (0.008)
Service size .....	0.3 (0.012), 0.6 (0.024) oversize	
<b>Piston</b>		
O.D. 4G91 .....	78.37 – 78.40 (3.0854 – 3.0866)	
4G92, 4G93 – non-turbo .....	80.97 – 81.00 (3.1878 – 3.1890)	
4G93 – Turbo .....	80.96 – 80.99 (3.1874 – 3.1886)	
Piston-to-cylinder clearance		
Non-turbo .....	0.02 – 0.04 (0.0008 – 0.0016)	
Turbo .....	0.03 – 0.05 (0.0012 – 0.0020)	
Service size .....	0.25 (0.01), 0.50 (0.02), 0.75 (0.03), 1.00 (0.04) oversize	
<b>Piston ring – Single camshaft engine</b>		
End gap		
No. 1 ring .....	0.25 – 0.40 (0.0098 – 0.0157)	0.8 (0.031)
No. 2 ring .....	0.40 – 0.55 (0.0157 – 0.0217)	0.8 (0.031)
Oil ring .....	0.20 – 0.60 (0.0079 – 0.0236)	1.0 (0.039)
Ring-to-ring groove clearance		
No. 1 ring .....	0.03 – 0.07 (0.0012 – 0.0028)	0.1 (0.004)
No. 2 ring .....	0.02 – 0.06 (0.0008 – 0.0024)	0.1 (0.004)
Service size .....	0.25 (0.01), 0.50 (0.02), 0.75 (0.03), 1.00 (0.04) oversize	
<b>Piston ring – Double camshaft engine</b>		
End gap		
No. 1 ring .....	0.25 – 0.40 (0.0098 – 0.0157)	0.8 (0.031)
No. 2 ring .....	0.40 – 0.55 (0.0157 – 0.0217)	0.8 (0.031)
Oil ring 4G91 .....	0.20 – 0.60 (0.0079 – 0.0236)	1.0 (0.039)
4G93 .....	0.10 – 0.35 (0.0039 – 0.0138)	1.0 (0.039)
Ring-to-ring groove clearance		
No. 1 ring .....	0.03 – 0.07 (0.0012 – 0.0028)	0.1 (0.004)
No. 2 ring .....	0.02 – 0.06 (0.0008 – 0.0024)	0.1 (0.004)
Service size .....	0.25 (0.01), 0.50 (0.02), 0.75 (0.03), 1.00 (0.04) oversize	
<b>Piston pin – Single camshaft engine</b>		
O.D. ....	19.002 – 19.005 (0.7481 – 0.7482)	
Press-in load N (kg, Psi) .....	5,000 – 15,000 (500 – 1,500, 1,102 – 3,307)	
Press-in-temperature .....	Room temperature	
<b>Piston pin – Double camshaft engine</b>		
O.D. 4G91 .....	19.002 – 19.005 (0.7481 – 0.7482)	
4G93 .....	19.001 – 19.007 (0.7481 – 0.7483)	
Press-in load N (kg, Psi) .....	5,000 – 15,000 (500 – 1,500, 1,102 – 3,307)	
Press-in-temperature .....	Room temperature	

	Standard	Limit
<b>Connecting rod</b>		
Big end center-to-small end center length	4G91, 4G92 ..... 119.9 – 120.0 (4.720 – 4.724)	
	4G93 ..... 133.4 – 133.5 (5.252 – 5.256)	
Bend	0.05 (0.0020)	
Twist	0.1 (0.004)	
Big end side clearance	0.10 – 0.25 (0.0039 – 0.0098)	0.4 (0.016)
<b>Crankshaft</b>		
End play	0.05 – 0.25 (0.0020 – 0.0098)	0.4 (0.016)
Journal O.D.	49.982 – 50.000 (1.9678 – 1.9685)	
Pin O.D.	44.980 – 45.000 (1.7709 – 1.7717)	
Out-of-roundness and taper of journal and pin	0.003 (0.0001)	
Oil clearance of journal	0.02 – 0.04 (0.0008 – 0.0016)	0.1 (0.004)
Oil clearance of pin	0.02 – 0.05 (0.0008 – 0.0020)	0.1 (0.004)
<b>Cylinder block</b>		
I.D.	4G91 ..... 78.40 – 78.43 (3.0866 – 3.0878)	
	4G92, 4G93 ..... 81.00 – 81.03 (3.1890 – 3.1902)	
Flatness of gasket surface	0.05 (0.020)	0.1 (0.004)
Grinding limit of gasket surface		*0.2 (0.008)
*Includes grinding of cylinder head.		
Overall height	4G91, 4G92 ..... 243.5 (9.59)	
	4G93 ..... 263.5 (10.37)	
<b>Flywheel</b>		
Runout		0.13 (0.0051)
<b>Oil pump</b>		
Tip clearance	0.03 – 0.08 (0.0012 – 0.0031)	
Side clearance	0.04 – 0.10 (0.0016 – 0.0039)	
Body clearance	0.10 – 0.18 (0.0039 – 0.0071)	
<b>Drive belt</b>		
Deflection		
Front wheel drive vehicle		
	New belt ..... 7.0 – 8.5 (0.28 – 0.33)	
	Used belt ..... 9.5 (0.37)	
Rear wheel drive vehicle		
	New belt ..... 6.0 – 8.0 (0.24 – 0.31)	
	Used belt ..... 8.5 – 9.5 (0.33 – 0.37)	
Tension N (kg, lbs.)		
Front wheel drive vehicle		
	New belt ..... 500 – 700 (50 – 70, 110 – 154)	
	Used belt ..... 400 (40, 88)	
Rear wheel drive vehicle		
	New belt ..... 650 – 850 (65 – 85, 143 – 187)	
	Used belt ..... 450 – 550 (45 – 55, 99 – 121)	

## TORQUE SPECIFICATIONS

	Nm	Torque kgm	ft.lbs.
<b>Ignition system</b>			
Spark plug .....	25	2.5	18
Distributor nut – Single camshaft engine for front wheel drive vehicle .....	12	1.2	9
Distributor bolt – Single camshaft engine for rear wheel drive vehicle .....	13	1.3	9
Crank angle sensor nut .....	12	1.2	9
– Double camshaft engine			
Ignition coil bolt .....	14	1.4	10
– Double camshaft engine			
Power transistor bolt .....	3	0.3	2.2
– Double camshaft engine			
Center cover bolt .....	3	0.3	2.2
– Double camshaft engine			
<b>Drive belt and timing belt</b>			
Crankshaft bolt .....	185	18.5	134
Alternator brace bolt .....	50	5.0	36
Alternator brace mounting bolt .....	23	2.3	17
Alternator pivot nut .....	45	4.5	33
Cooling fan .....	9	0.9	7
Fan clutch .....	11	1.1	8
Distributor bracket bolt .....	24	2.4	18
Camshaft sprocket bolt .....			
Timing belt tensioner bolt .....	24	2.4	18
– Single camshaft engine			
Timing belt tensioner spring bolt .....	45	4.5	33
– Single camshaft engine			
Camshaft sprocket bolt .....	90	9.0	65
Oil level gauge guide mounting bolt .....	11	1.1	8
Oil level gauge guide mounting bolt .....	14	1.4	10
– for rear wheel drive vehicle			
Tensioner pulley bolt .....	49	4.9	35
– Double camshaft engine			
Tensioner arm bolt .....	45	4.5	33
– Double camshaft engine			
Auto tensioner bolt .....	14	1.4	10
– Double camshaft engine			
Idler pulley bolt .....	36	3.6	26
– Double camshaft engine			
<b>Fuel and emission control system</b>			
Throttle position sensor bolt .....	2	0.2	1.4
Throttle body mounting bolt .....	19	1.9	14
Delivery pipe mounting bolt .....	12	1.2	9
Fuel pressure regulator bolt .....	9	0.9	7
Fuel vapor separator .....	18	1.8	13
Carburetor bolt .....	18	1.8	13
Breather tube bolt .....	32	3.2	23
Throttle body stay .....	19	1.9	14
EGR valve .....	22	2.2	16

	Nm	Torque kgm	ft.lbs:
<b>Intake manifold and water pump</b>			
Intake manifold stay mounting bolt .....	31	3.1	22
Intake manifold mounting bolt .....	19	1.9	14
Intake manifold mounting nut .....	19	1.9	14
Water pump mounting bolt .....	24	2.4	18
Timing belt cover mounting bolt .....	10	1.0	7
Engine support bracket left mounting bolt .....	50	5.0	36
Water pipe mounting bolt .....	14	1.4	10
Engine coolant temperature sensor .....	30	3.0	22
Engine coolant temperature gauge unit .....	11	1.1	8
Thermostat housing mounting bolt .....	24	2.4	18
Water outlet fitting mounting bolt .....	19	1.9	14
<b>Exhaust manifold</b>			
Oxygen sensor .....	45	4.5	33
Exhaust manifold cover "A" mounting bolt .....	27	2.7	20
Exhaust manifold cover "A" mounting bolt .....	9	0.9	7
Exhaust manifold cover "B" mounting bolt .....	24	2.4	17
Exhaust manifold cover .....	30	3.0	22
Exhaust manifold bracket mounting bolt .....	36	3.6	26
Exhaust manifold mounting nut			
Engine without turbocharger .....	M8 .....	1.8	13
M10 .....	30	3.0	22
Engine with turbocharger .....	M8 .....	2.8	20
M10 .....	43	4.3	31
Heat protector mounting bolt .....	M6 .....	0.9	7
M8 .....	14	1.4	10
Air outlet fitting mounting bolt .....	19	1.9	14
Eye bolt (for oil pipe) .....	17	1.7	12
Eye bolt (for water pipe) .....	31	3.1	22
Oil return pipe bolt .....	9	0.9	7
Exhaust fitting bracket bolt .....	M8 .....	1.9	14
M10 .....	36	3.6	26
Turbocharger mounting bolt .....	60	6.0	43
Oil pipe bolt .....	9	0.9	7
Water pipe bolt .....	11	1.1	8
<b>Rocker arms and camshaft</b>			
Rocker cover mounting bolt .....	3.3	0.33	2.4
Rocker arm shaft mounting bolt .....	32	3.2	23
– Single camshaft engine			
Adjusting screw lock nut .....	9	0.9	7
– Single camshaft engine			
Bearing cap bolt .....	M6 .....	1.1	8
– Double camshaft engine	M8 .....	2.4	18
Thrust case .....	14	1.4	10
<b>Cylinder head and valves</b>			
Engine hanger mounting bolt .....	12	1.2	9
Water outlet fitting mounting bolt .....	14	1.4	10
Water outlet hole cover .....	14	1.4	10

	Nm	Torque kgm	ft.lbs.
Oil pressure switch .....	10	1.0	7
Cylinder head bolt .....	20 + 90° + 90°	2.0 + 90° +90°	14.5 + 90° + 90°
[Tighten to 74 Nm (7.5 kgm, 54 ft.lbs) and then completely loosen before finally tightening with above procedure.]			
<b>Front case and oil pump</b>			
Drain plug .....	40	4.0	29
Oil pan mounting bolt .....	7	0.7	5
Oil screen .....	19	1.9	14
Relief plug .....	45	4.5	35
Oil pump case mounting bolt .....	14	1.4	11
Oil pump case mounting bolt .....	10	1.0	7
<b>Front case and oil pump</b>			
Water pipe mounting bolt .....	11	1.1	8
Oil cooler bolt .....	43	4.3	31
Baffle plate mounting bolt .....	11	1.1	8
<b>Piston and connecting rod</b>			
Connecting rod cap nut .....	20 + 90°	2.0 + 90°	14.5 + 90°
<b>Crankshaft, cylinder block, flywheel and drive plate</b>			
Flywheel bolt .....	100	10.0	72
Drive plate bolt .....	100	10.0	72
Rear plate mounting bolt .....	11	1.1	8
Bell housing cover mounting bolt .....	9	0.9	7
Oil seal case mounting bolt .....	11	1.1	8
Bearing cap bolt .....	25 + 90°	2.5 + 90°	18 + 90°

**NEW TIGHTENING METHOD – BY USE OF BOLTS TO BE TIGHTENED IN PLASTIC AREA**

A new type of bolts, to be tightened in plastic area, is currently used in some parts of the engine. The tightening method for the bolts is different from the conventional one. Be sure to observe the method described in the text when tightening the bolts.

Service limits are provided for the bolts. Make sure that the service limits described in the text are strictly observed.

- Areas where the bolts are in use:

- (1) Cylinder head bolts
- (2) Main bearing cap bolts
- (3) Connecting rod cap bolts

- Tightening Method

After tightening the bolts to the specified torque, tighten them another 90° or 180° (twice 90°). The tightening method varies on different areas. Observe the tightening method described in the text.

**SEALANT**

	Specified sealant	Quantity
Water pump .....	Mitsubishi Genuine Part No. MD970389 .....	As required or equivalent
Thermostat housing .....	Mitsubishi Genuine Part No. MD970389 .....	As required or equivalent
Engine coolant temperature sensor .....	3M Nut Locking part No. 4171 or equivalent .....	As required
Engine coolant temperature gauge unit .....	3M ATD Part No. 8660 or equivalent .....	As required
Camshaft bearing cap .....	3M ATD Part No. 8660 or equivalent .....	As required
Semi-circular packing .....	3M ATD Part No. 8660 or equivalent .....	As required
Rocker cover .....	3M ATD Part No. 8660 or equivalent .....	As required
Oil pressure switch .....	3M ATD Part No. 8660 or equivalent .....	As required
Water outlet fitting .....	Mitsubishi Genuine Part No. MD970389 .....	As required or equivalent
Oil pump case .....	Mitsubishi Genuine Part No. MD970389 .....	As required or equivalent
Oil pan .....	Mitsubishi Genuine Part No. MD970389 .....	As required or equivalent
Oil seal case .....	Mitsubishi Genuine Part No. MD970389 .....	As required or equivalent
Drive plate bolt .....	3M Nut Locking part No. 4171 or equivalent .....	As required
Flywheel bolt .....	3M Nut Locking part No. 4171 or equivalent .....	As required

## FORM-IN-PLACE GASKET

The engine has several areas where the form-in-place gasket (FIPG) is in use. To ensure that the gasket fully serves its purpose, it is necessary to observe some precautions when applying the gasket. Bead size, continuity and location are of paramount importance. Too thin a bead could cause leaks. Too thick a bead, on the other hand, could be squeezed out of location, causing blocking or narrowing of the fluid feed line. To eliminate the possibility of leaks from a joint, therefore, it is absolutely necessary to apply the gasket evenly without a break, while observing the correct bead size.

The FIPG used in the engine is a room temperature vulcanization (RTV) type and is supplied in a 100-gram tube (Part No. MD970389 or MD997110). Since the RTV hardens as it reacts with the moisture in the atmospheric air, it is normally used in the metallic flange areas. The FIPG, Part No. MD970389, can be used for sealing both engine oil and coolant, while Part No. 997110 can only be used for engine oil sealing.

### Disassembly

The parts assembled with the FIPG can be easily disassembled without use of a special method. In some cases, however, the sealant between the joined surfaces may have to be broken by lightly striking with a mallet or similar tool. A flat and thin gasket scraper may be lightly hammered in between the joined surfaces. In this case, however, care must be taken to prevent damage to the joined surfaces. For removal of the oil pan, the special tool "Oil Pan Remover" (MD998727) is available. Be sure to use the special tool to remove the oil pan.

### Surface Preparation

Thoroughly remove all substances deposited on the gasket application surfaces, using a gasket scraper or wire brush. Check to ensure that the surfaces to which the FIPG is to be applied is flat. Make sure that there are no oils, greases and foreign substances deposited on the application surfaces. Do not forget to remove the old sealant remained in the bolt holes.



### Form-In-Place Gasket Application

When assembling parts with the FIPG, you must observe some precautions, but the procedure is very simple as in the case of a conventional pre-cut gasket.

Applied FIPG bead should be of the specified size and without breaks. Also be sure to encircle the bolt hole circumference with a completely continuous bead. The FIPG can be wiped away unless it is hardened. While the FIPG is still moist (in less than 15 minutes), mount the parts in position. When the parts are mounted, make sure that the gasket is applied to the required area only.

The FIPG application procedure may vary on different areas. Observe the procedure described in the text when applying the FIPG.

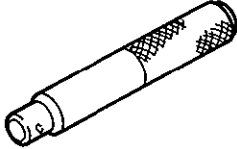
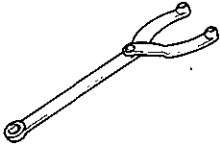
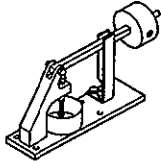
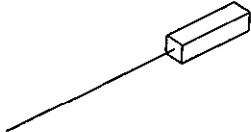
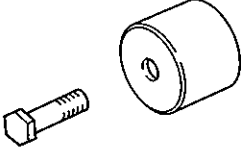

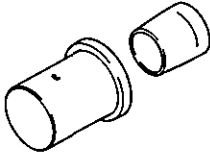
## 2. SPECIAL TOOLS

Tool	Number	Name	Use
	MB990938	Handle	Use with MD998776
	MB990767	Crankshaft pulley holder	Holding camshaft sprocket or crankshaft pulley when loosening and tightening of bolt. Use with MD998719
	MB998440	Leak-down tester	Leak-down test of lash adjuster
	MB998442	Air bleed wire	Air bleeding of lash adjuster
	MD998713	Camshaft oil seal installer	Installation of camshaft oil seal
	MD998716	Crankshaft wrench	Rotation of crankshaft when installing piston and timing belt.
	MD998717	Crankshaft front oil seal installer	Installation of crankshaft front oil seal

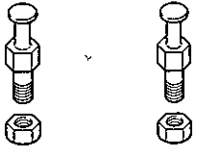
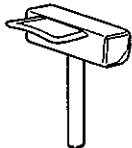
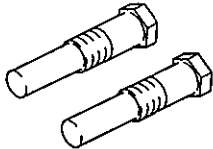
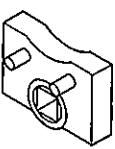
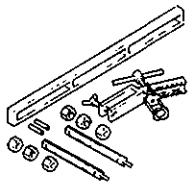
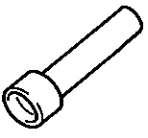
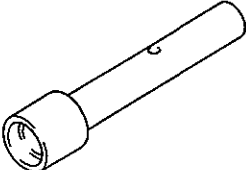

Tool	Number	Name	Use
	MD998719	Pulley holder pin (2)	Use with MB990767
	MD998727	Oil pan remover	Removal of the oil pan
	MD998754	Pin	Used with MB990767
	MD998767	Tensioner pulley socket wrench	Adjustment of timing belt tension
	MD998772	Valve spring compressor	Removal and installation of valve and related parts
	MD998774	Valve stem seal installer	Installation of valve stem seal
	MD998775	Valve stem seal staller	Installation of valve stem seal

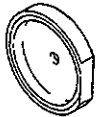
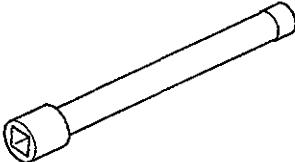
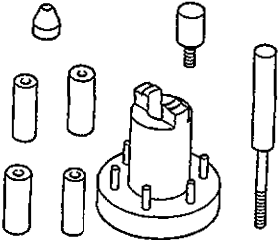
512

Tool	Number	Name	Use
	MD998776	Crankshaft rear oil seal installer	Installation of crankshaft rear oil seal Use with MB990938
	MB991653	Cylinder head bolt wrench	Loosening and tightening of cylinder head bolt
	MD998780	SETTING TOOL	Removal and installation of piston pin
	MB991659	Guide D	Removal of piston pin

---

NOTES

### 3. IGNITION SYSTEM (SINGLE CAMSHAFT ENGINE)

#### REMOVAL AND INSTALLATION (FRONT WHEEL DRIVE VEHICLE)

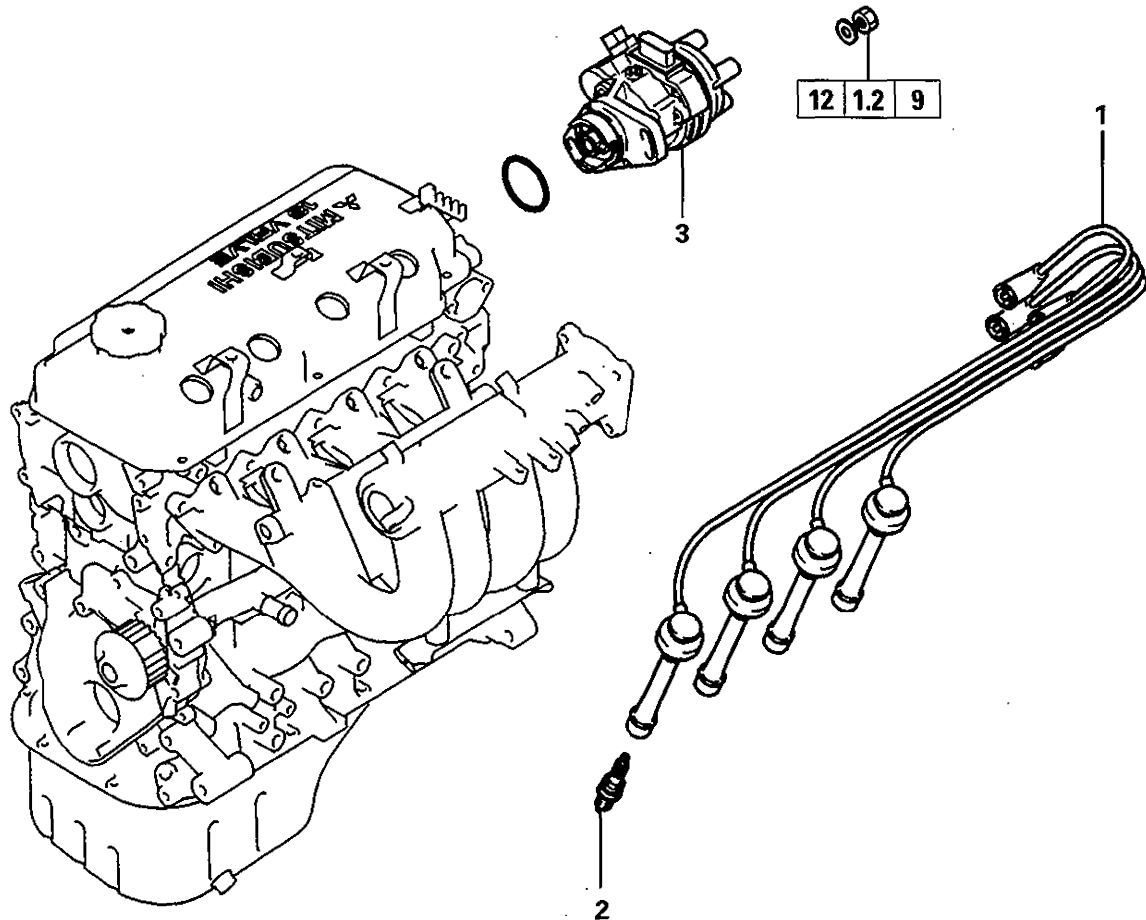

#### Removal steps

1. Spark plug cable
2. Spark plug
- ◆◆ 3. Distributor

## REMOVAL AND INSTALLATION (REAR WHEEL DRIVE VEHICLE)

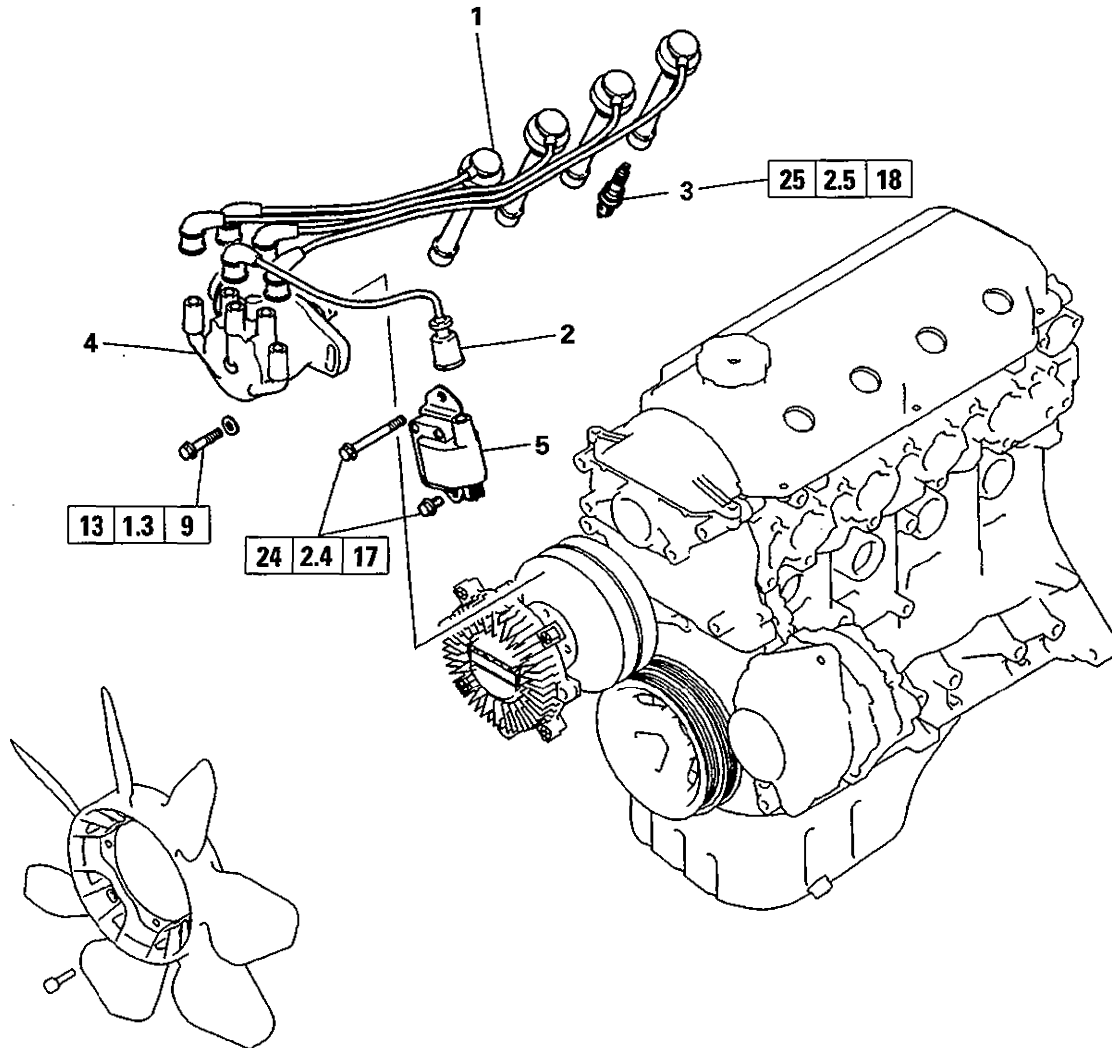
**Removal steps**

1. Spark plug cable
2. High tension cable
3. Spark plug
- ▶B◀ 4. Distributor
5. Ignition coil

**NOTE**

If the distributor and/or ignition coil are to be removed, remove the cooling fan beforehand. For the removal and installation procedures of the cooling fan, refer to 11A-5-2.

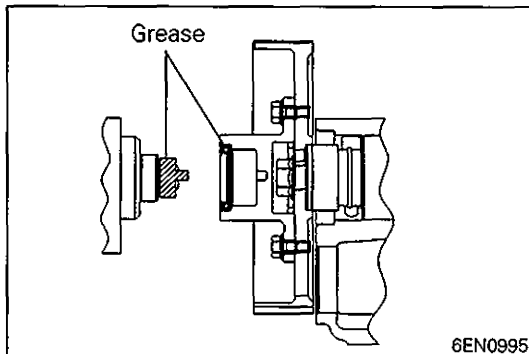
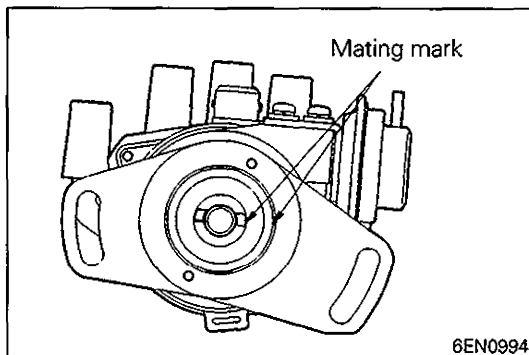
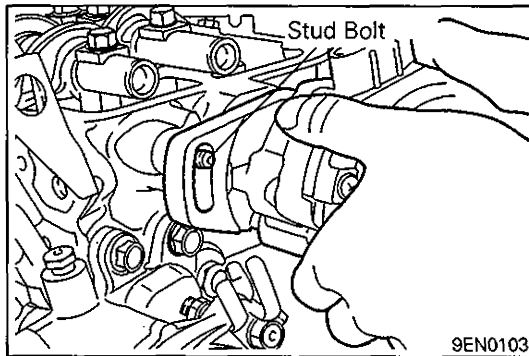
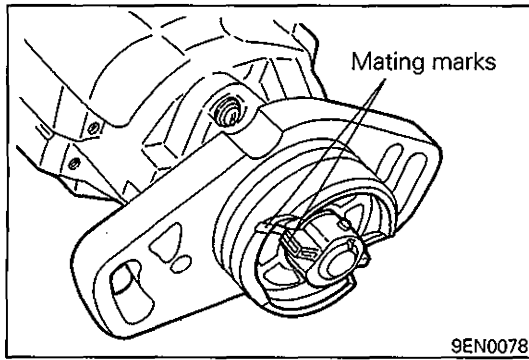

## SERVICE POINT OF INSTALLATION

### ◆A◆ INSTALLATION OF DISTRIBUTOR ASSEMBLY

- (1) Turn the crankshaft to bring No. 1 cylinder to the top dead center on compression stroke.
- (2) Align the mating marks on the distributor housing with that of the coupling key.

- (3) Install the distributor assembly on the engine while aligning the stud bolt used for securing the distributor with the slot in the mounting flange of the distributor.

### ◆B◆ DISTRIBUTOR INSTALLATION

- (1) Turn the crankshaft clockwise and set the No. 1 cylinder piston at the top dead center of the compression stroke.
- (2) Align mating marks on the distributor housing and the coupling.

- (3) Apply grease sparingly to the distributor coupling and the entire surface of the oil seal lip and install the distributor.

**Specified grease: Multipurpose grease SAEJ310,  
NLGI No. 3**

---

NOTES

# 4. IGNITION SYSTEM (DOUBLE CAMSHAFT ENGINE)

## REMOVAL AND INSTALLATION

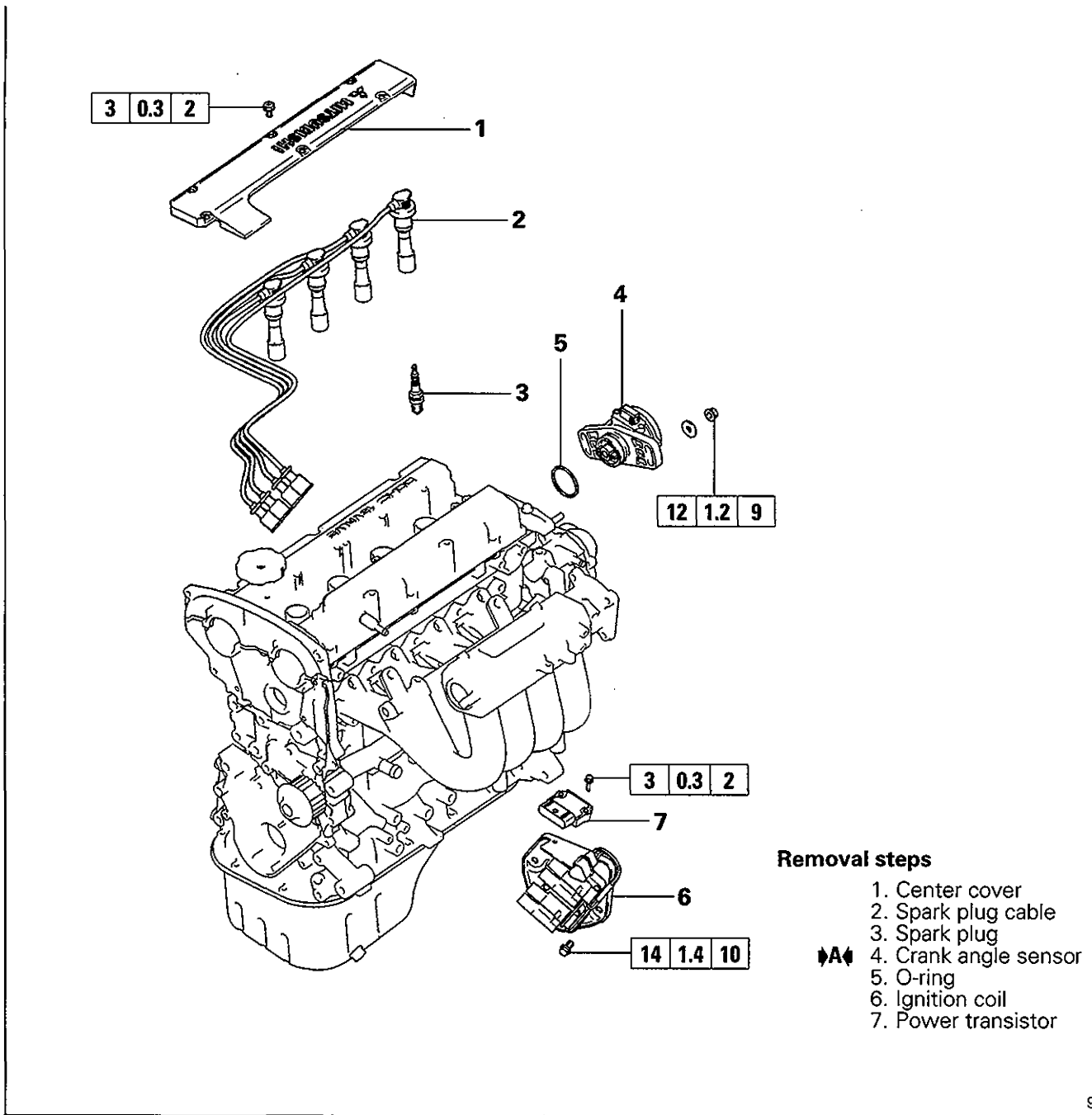

9EN0155

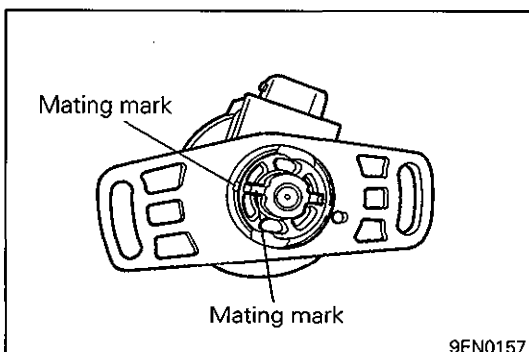

### SERVICE POINTS OF INSTALLATION

#### ▶A▶ INSTALLATION OF CRANK ANGLE SENSOR

- (1) Turn the crankshaft so that the No. 1 cylinder is at top dead center.
- (2) Align the punch mark on the crank angle sensor housing with the notch in plate.
- (3) Install the crank angle sensor on the cylinder head.



---

NOTES

# 5. DRIVE BELT AND TIMING BELT (SINGLE CAMSHAFT ENGINE)

## REMOVAL AND INSTALLATION

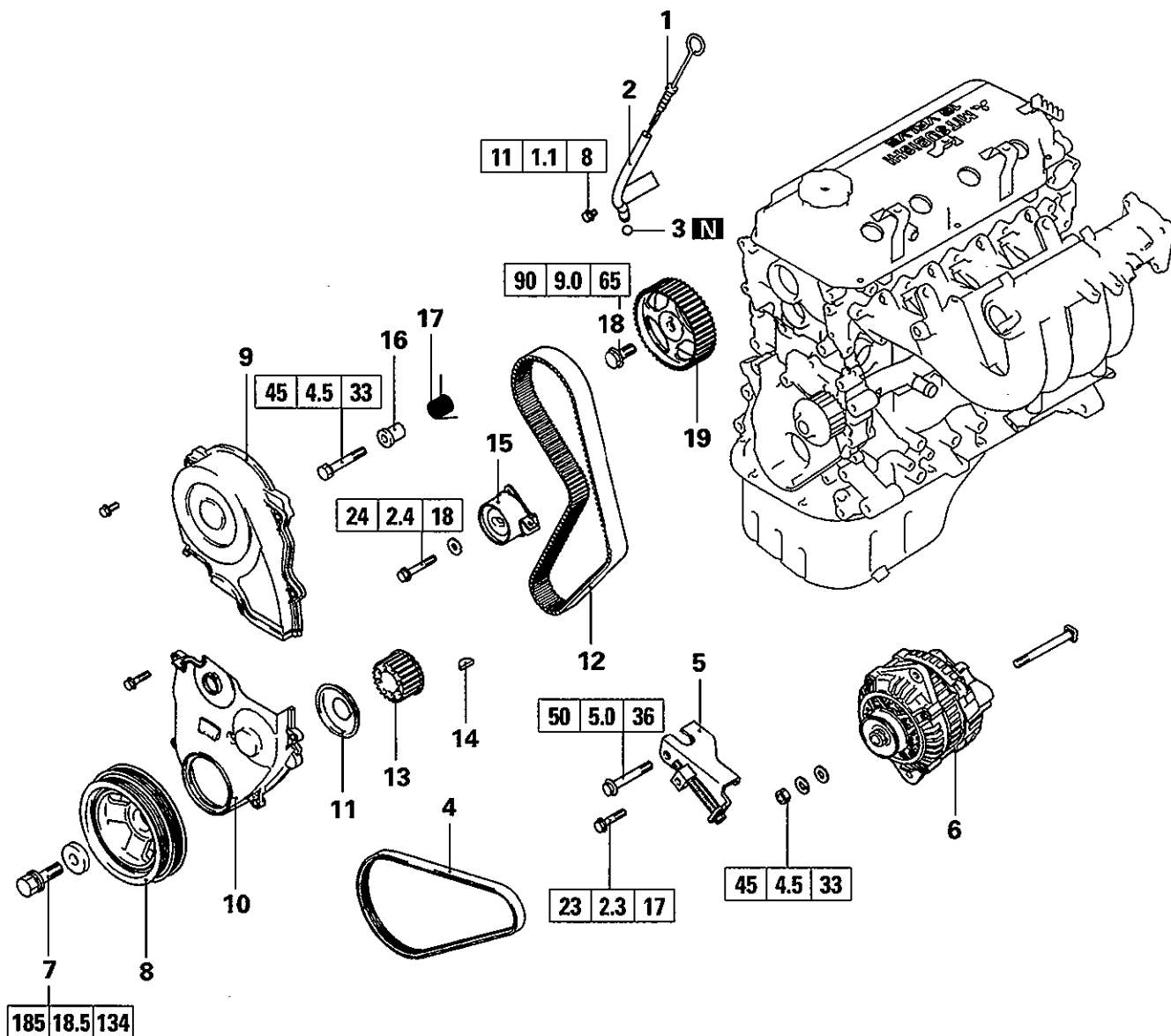

### Removal steps

- |         |                             |         |                            |
|---------|-----------------------------|---------|----------------------------|
|         | 1. Oil level gauge          |         | 11. Flange                 |
|         | 2. Oil level gauge guide    |         | 12. Timing belt            |
|         | 3. O-ring                   | ◁B▷ ▷C◁ | 13. Crankshaft sprocket    |
| ▷E◁     | 4. Drive belt               |         | 14. Crankshaft key         |
|         | 5. Alternator brace         | ▷B◁     | 15. Timing belt tensioner  |
|         | 6. Alternator               |         | 16. Tensioner spacer       |
| ◁A▷ ▷D◁ | 7. Crankshaft bolt          | ▷B◁     | 17. Tensioner spring       |
|         | 8. Crankshaft pulley        | ◁C▷ ▷A◁ | 18. Camshaft sprocket bolt |
|         | 9. Timing belt upper cover  |         | 19. Camshaft sprocket      |
|         | 10. Timing belt lower cover |         |                            |

REMOVAL AND INSTALLATION

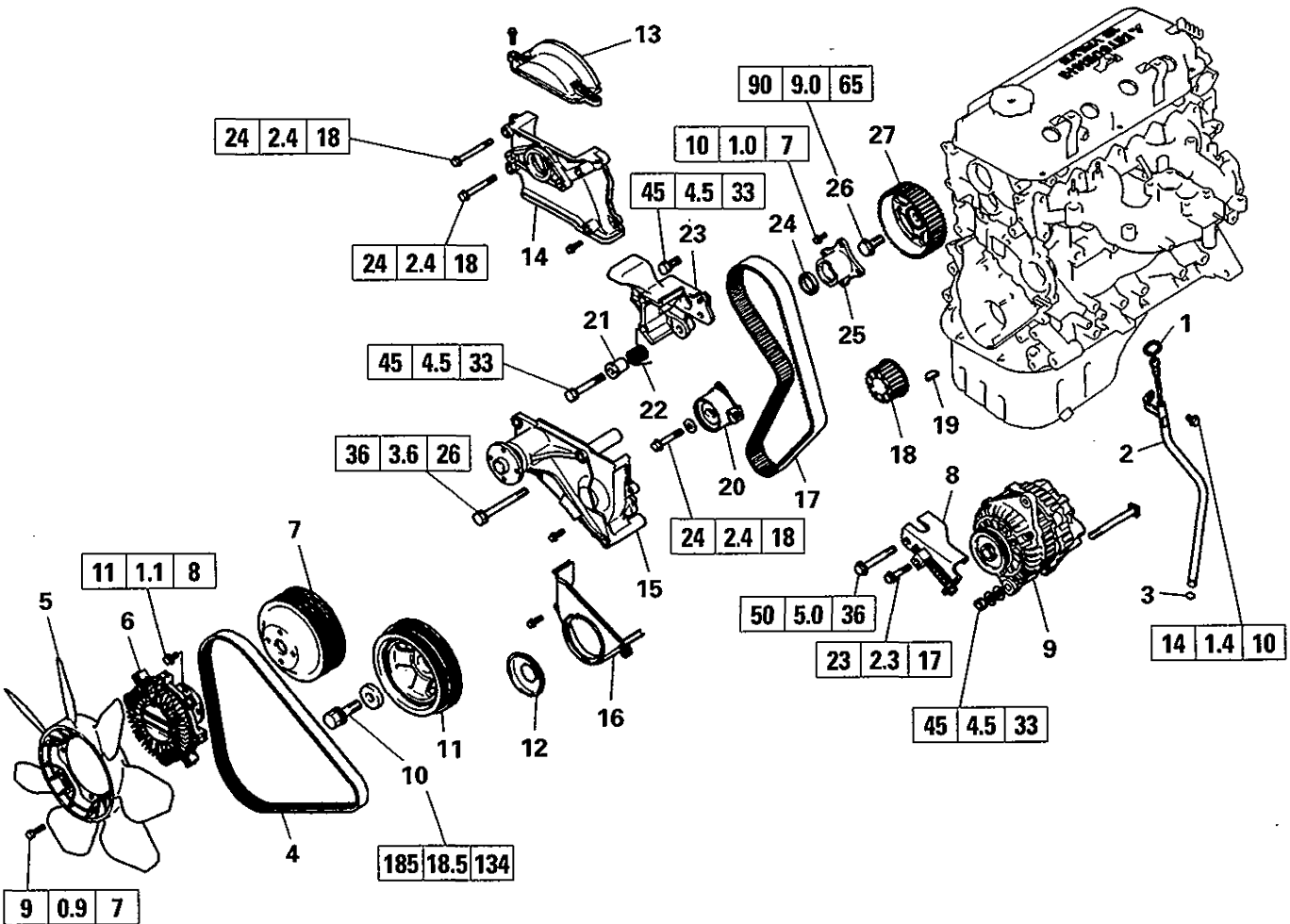

Removal steps

- |  |   |
|--|---|
| <ul style="list-style-type: none"> <li>1. Oil level gauge</li> <li>2. Oil level gauge guide</li> <li>3. O-ring</li> <li>▶E◀ 4. Drive belt</li> <li>5. Cooling fan</li> <li>6. Fan clutch</li> <li>7. Fan pulley</li> <li>8. Alternator brace</li> <li>9. Alternator</li> <li>◀A▶ ▶D▶ 10. Crankshaft bolt</li> <li>11. Crankshaft pulley</li> <li>12. Flange</li> <li>13. Timing belt upper cover</li> <li>14. Distributor bracket</li> </ul> | <ul style="list-style-type: none"> <li>15. Cooling fan bracket</li> <li>16. Timing belt lower cover</li> <li>◀B▶ ▶C▶ 17. Timing belt</li> <li>18. Crankshaft sprocket</li> <li>19. Crankshaft key</li> <li>▶B▶ 20. Timing belt tensioner</li> <li>21. Tensioner spacer</li> <li>▶B▶ 22. Tensioner spring</li> <li>23. Timing belt tensioner bracket</li> <li>▶G▶ 24. Oil seal</li> <li>▶F▶ 25. Camshaft sprocket spacer</li> <li>◀C▶ ▶A▶ 18. Camshaft sprocket bolt</li> <li>19. Camshaft sprocket</li> </ul> |
|--|---|

502

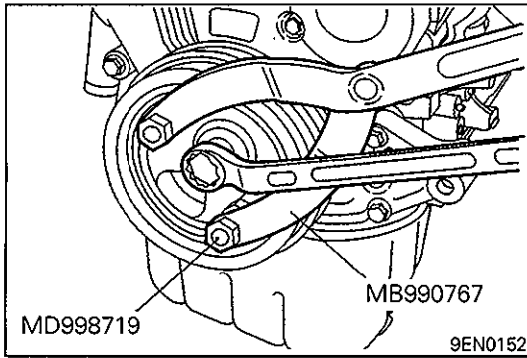
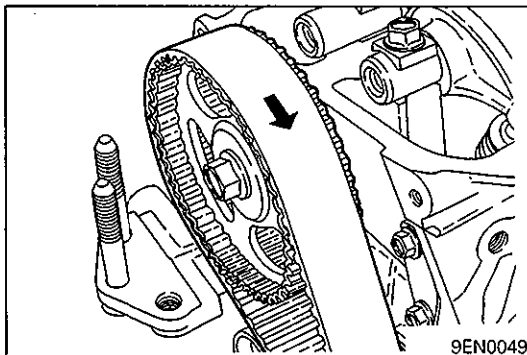
**SERVICE POINTS OF REMOVAL****◁A▷ REMOVAL OF CRANKSHAFT BOLT****◁B▷ REMOVAL OF TIMING BELT**

(1) Mark belt running direction for reinstallation.

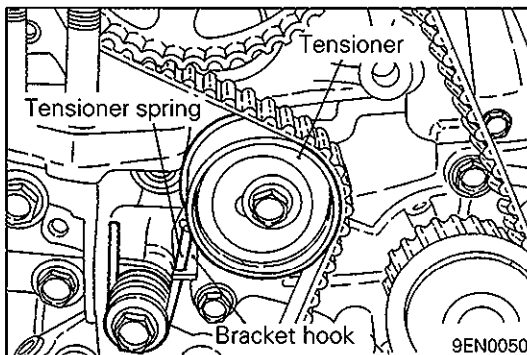

(2) Back off the tensioner spring mounting bolt three turns.

(3) Pinching the end of the tensioner spring on the tensioner side with pliers, unhook it from the bracket hook on the tensioner to free the tensioner spring.

(4) Loosen the tensioner mounting bolt and remove the timing belt.

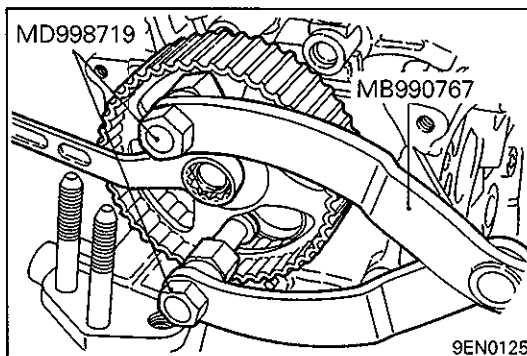
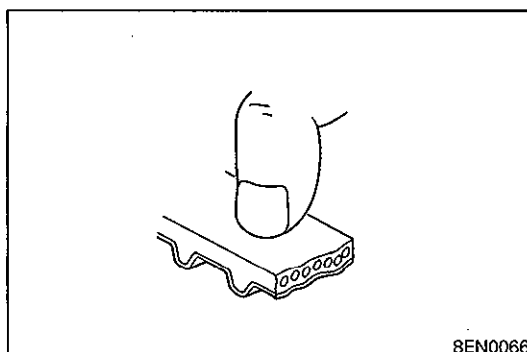
**◁C▷ LOOSENING OF CAMSHAFT SPROCKET BOLT****INSPECTION****TIMING BELT**

Replace belt if any of the following conditions exist.

(1) Hardening of back rubber.

Back side is glossy without resilience and leaves no indent when pressed with fingernail.

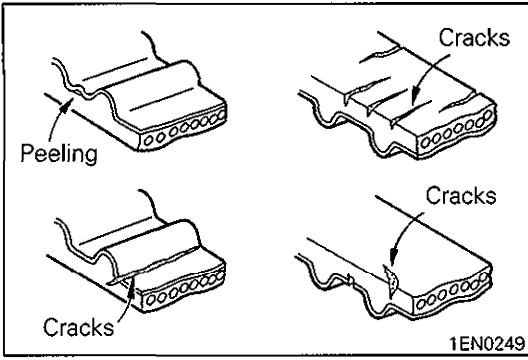

- (2) Cracks on rubber back.
- (3) Cracks or peeling of canvas.
- (4) Cracks on tooth bottom.
- (5) Cracks on belt sides.

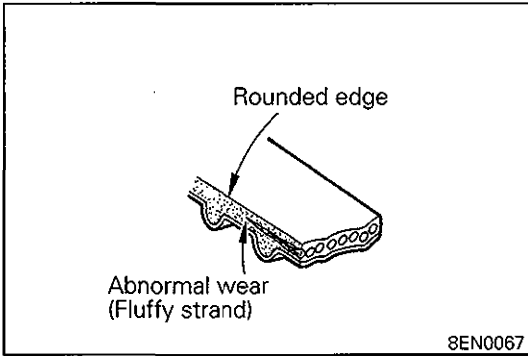

- (6) Abnormal wear of belt sides. The sides are normal if they are sharp as if cut by a knife.

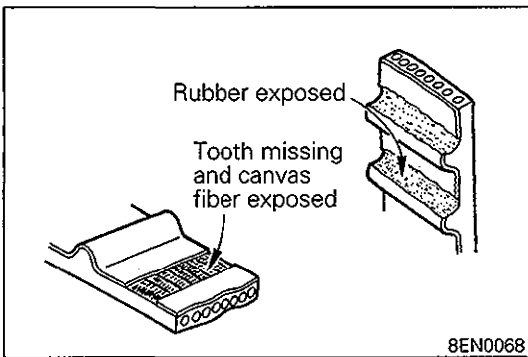

- (7) Abnormal wear on teeth.
- (8) Missing tooth.

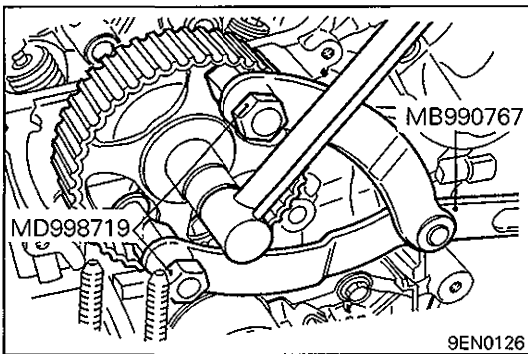

**SERVICE POINTS OF INSTALLATION**

**▶◀ TIGHTENING OF CAMSHAFT SPROCKET BOLT**

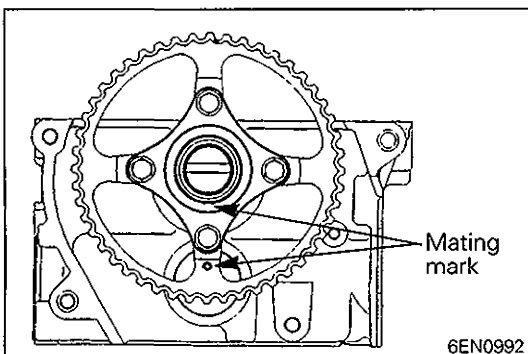

**▶◀ CAMSHAFT SPROCKET SPACER INSTALLATION**

- (1) To install the spacer, align mating marks on camshaft sprocket and camshaft sprocket spacer as shown.

524

**▶G▶ OIL SEAL INSTALLATION**

- (1) Lightly strike the oil seal into the camshaft sprocket spacer until it seats to its position securely.

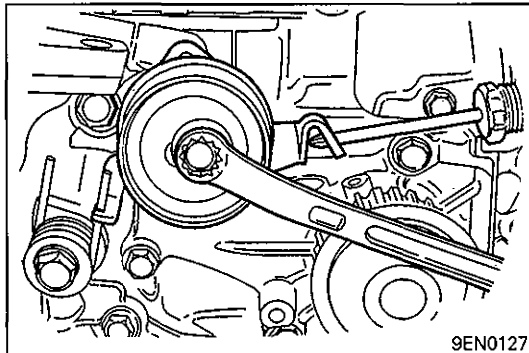
**▶B▶ INSTALLATION OF TENSIONER SPRING / TIMING BELT TENSIONER**

- (1) Install the tensioner spring and spacer. Fully tighten the bolt, then back it off three turns.
- (2) Mount the timing belt tensioner.
- (3) Hook the spring end onto the tensioner.

**Caution**

- **When hooking the tensioner spring use care not to damage the outer periphery of the tensioner pulley with the spring end.**

- (4) Insert a screwdriver in the tensioner as shown in the illustration. Fully push the tensioner in the direction of the arrow and tighten the bolt to secure the tensioner in that position.
- (5) Tighten the tensioner spring lock bolt to the specification.

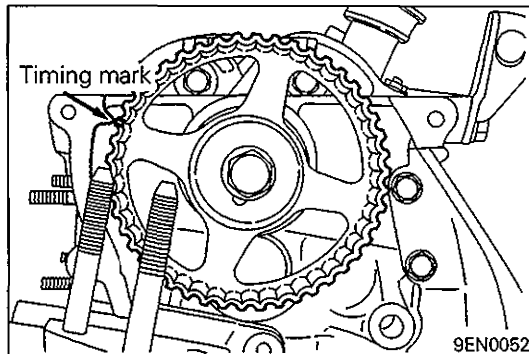
**▶C▶ INSTALLATION OF TIMING BELT**

- (1) Check that the timing belt tensioner and spring have been installed in position. (See ▶B▶.)
- (2) Align timing mark on camshaft sprocket with timing mark on cylinder head.

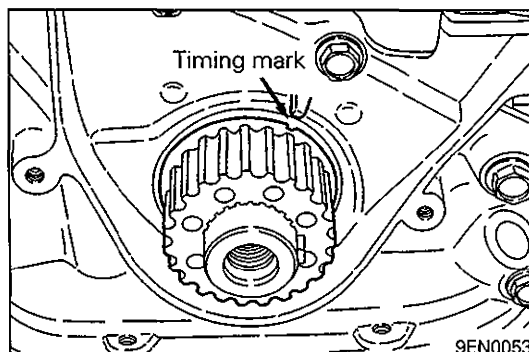

- (3) Align timing mark on crankshaft sprocket with timing mark on front case.

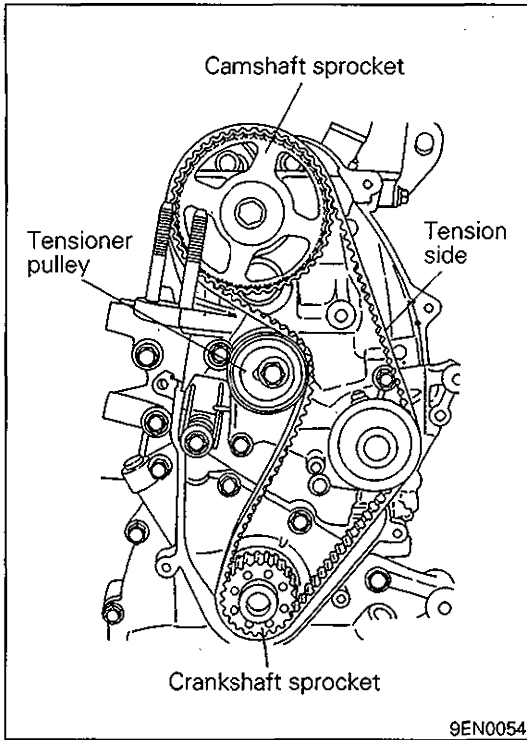

- (4) Install the timing belt first on crankshaft sprocket and then keeping the tension side belt tight, set on the camshaft sprocket. Finally, set the belt on the tensioner pulley.

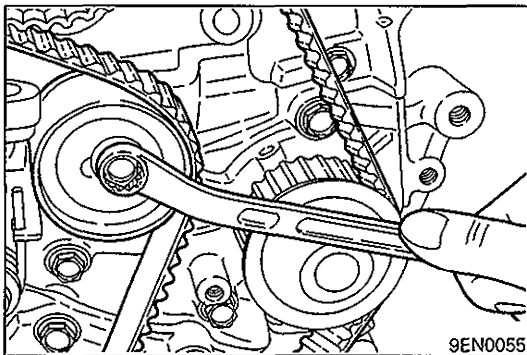

- (5) Back off one turn the tensioner pulley mounting bolt which has been temporarily tightened.

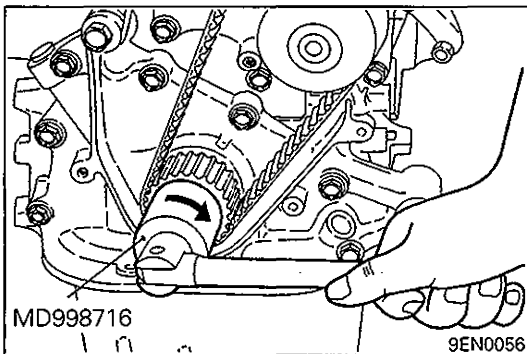

- (6) Turn the crankshaft clockwise two turns.  
 (7) Check that the timing marks are properly aligned.  
 (8) Tighten the tensioner pulley mounting bolt to specification.

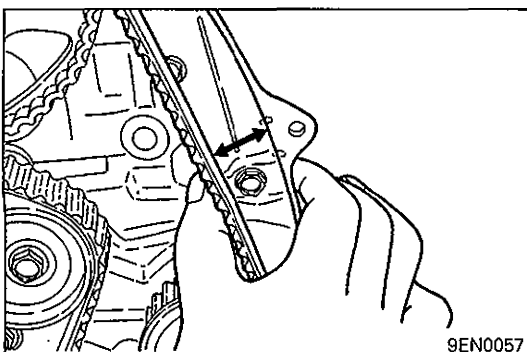

- (9) Check that there is a clearance of 30 mm (1.18 in.) between the back side of the timing belt and the inside of undercover seal line.

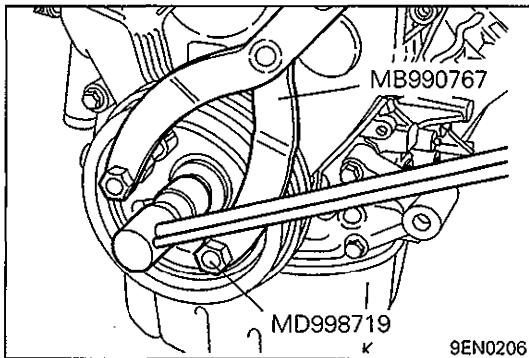

### ◆D◆ INSTALLATION OF CRANKSHAFT BOLT

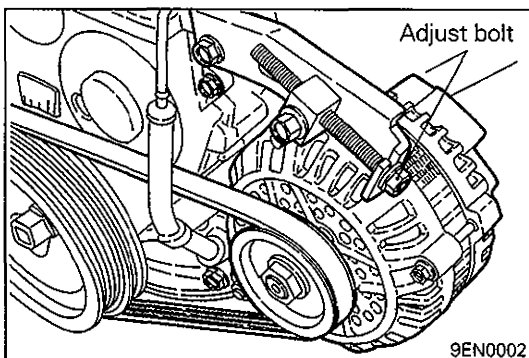

### ◆E◆ ADJUSTMENT OF DRIVE BELT TENSION

- (1) Adjust belt deflection with adjusting bolt to standard value.

#### Standard value:

##### Front wheel drive vehicle

New belt 7.0 – 8.5 mm (0.28 – 0.33 in.)

Used belt 9.5 mm (0.37 in.)

##### Rear wheel drive vehicle

New belt 6.0 – 8.0 mm (0.24 – 0.31 in.)

Used belt 8.5 – 9.5 mm (0.33 – 0.37 in.)

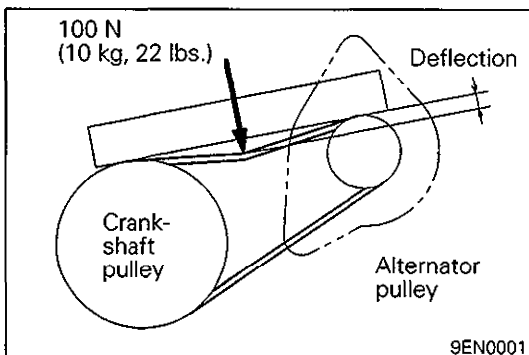

- (2) Or using tension gauge, adjust tension to standard value.

#### Standard value:

##### Front wheel drive vehicle

New belt 500 – 700 N (50 – 70 kg, 110 – 154 lbs.)

Used belt 400 N (40 kg, 88 lbs.)

##### Rear wheel drive vehicle

New belt 650 – 850 N (65 – 85 kg, 143 – 187 lbs.)

Used belt 450 – 550 N (45 – 55 kg, 99 – 121 lbs.)

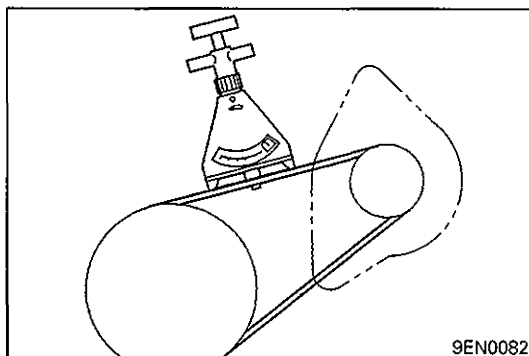

- (3) Tighten lock bolt to the specified torque.  
 (4) Tighten nut for pivot bolt to the specified torque.



---

NOTES

# 6. DRIVE BELT AND TIMING BELT (DOUBLE CAMSHAFT ENGINE)

## REMOVAL AND INSTALLATION

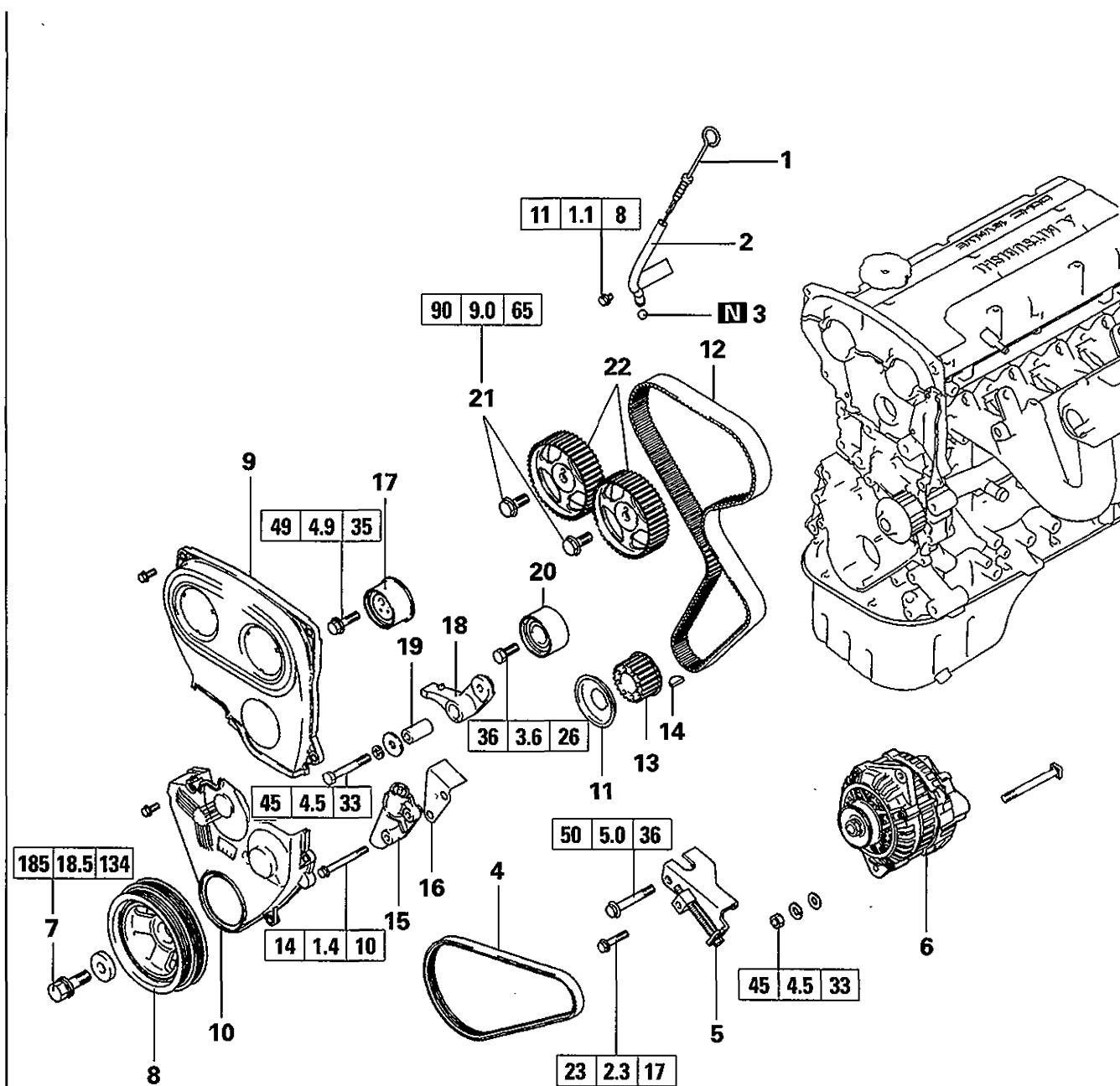

### Removal steps

- |        |                             |        |                            |
|--------|-----------------------------|--------|----------------------------|
|        | 1. Oil level gauge          |        | 12. Timing belt            |
|        | 2. Oil level gauge guide    |        | 13. Crankshaft sprocket    |
|        | 3. O-ring                   |        | 14. Crankshaft key         |
| ↔E↔    | 4. Drive belt               | ↔B↔↔C↔ | 15. Auto tensioner         |
|        | 5. Alternator brace         | ↔B↔    | 16. Auto tensioner pulley  |
|        | 6. Alternator               |        | 17. Tensioner pulley       |
| ↔A↔↔D↔ | 7. Crankshaft bolt          |        | 18. Tensioner arm          |
|        | 8. Crankshaft pulley        |        | 19. Spacer                 |
|        | 9. Timing belt upper cover  |        | 20. Idler pulley           |
|        | 10. Timing belt lower cover | ↔C↔↔A↔ | 21. Camshaft sprocket bolt |
|        | 11. Flange                  |        | 22. Camshaft sprocket      |

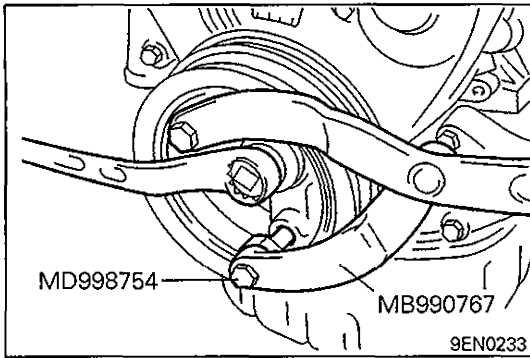
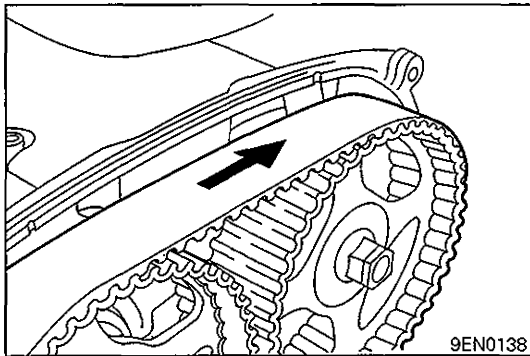
**SERVICE POINTS OF REMOVAL****◁A▷ LOOSENING OF CRANKSHAFT BOLT****◁B▷ REMOVAL OF TIMING BELT**

(1) Mark belt running direction for reinstallation.

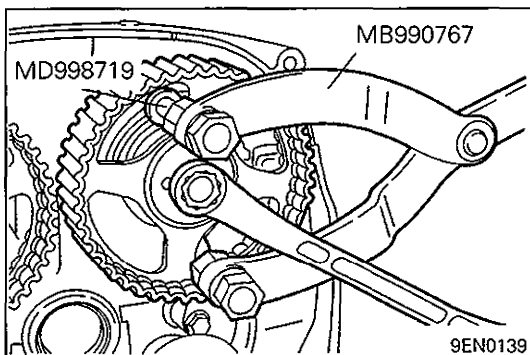
**◁C▷ LOOSENING OF CAMSHAFT SPROCKET BOLT****INSPECTION****TIMING BELTS**

Refer to "INSPECTION" on Page 11A-5-3.

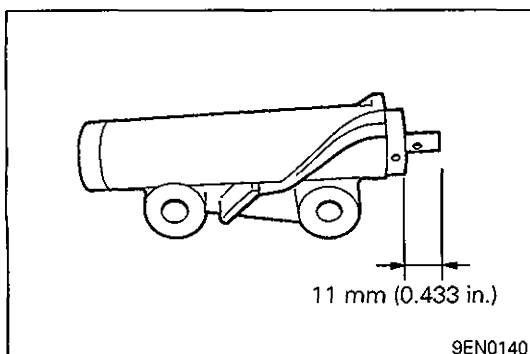
**AUTO-TENSIONER**

- (1) Check for oil leaks. If oil leaks are evident, replace the auto-tensioner.
- (2) Check the rod end for wear or damage and replace the auto-tensioner if necessary.
- (3) Measure the rod projection length. If the reading is outside the standard value, replace the auto tensioner.

**Standard value: 11 mm (0.433 in.)**

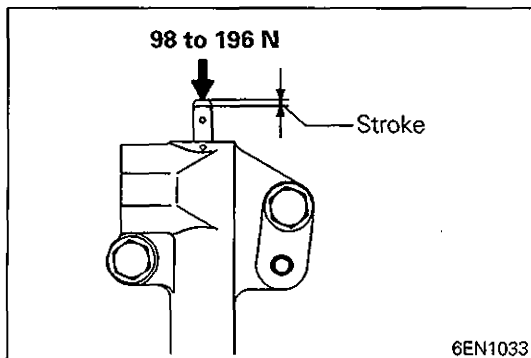

- (4) Press the rod by a force of 98 to 196 N and measure the rod stroke. If not within the standard value, replace the tensioner.

**Standard value: 1 mm or less**

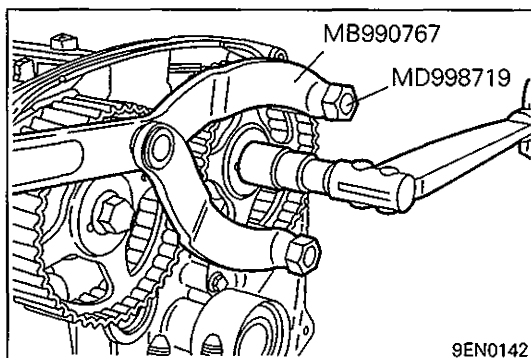

## SERVICE POINTS OF INSTALLATION

### ▶A◀ TIGHTENING OF CAMSHAFT SPROCKET BOLT

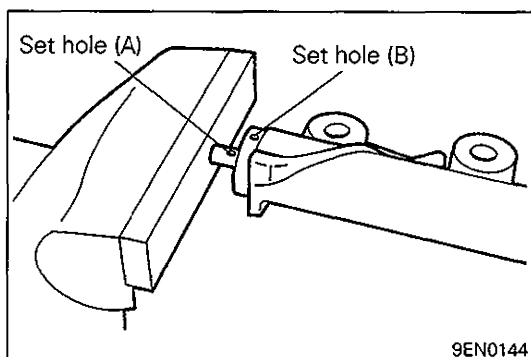

### ▶B◀ INSTALLATION OF AUTO-TENSIONER

- (1) If the auto-tensioner rod is fully extended, set it in the retracted position with the following procedure.

- ① Set the auto tensioner in a vice, while making sure it is not tilted.
- ② Slowly close the vice to force the rod in until the set hole (A) of the rod is lined up with the set hole (B) of the cylinder.

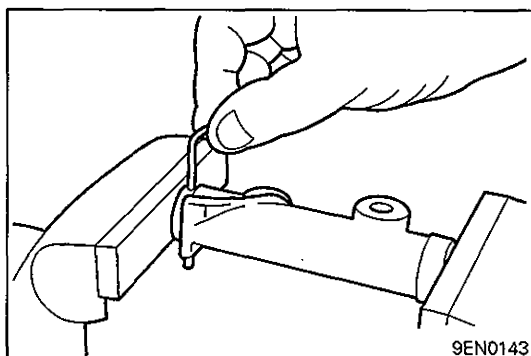

- ③ Insert a 2 mm Allen wrench in the set hole.
- ④ Remove the auto tensioner from the vice.

- (2) Install the auto tensioner on the cylinder block through the oil pump case.

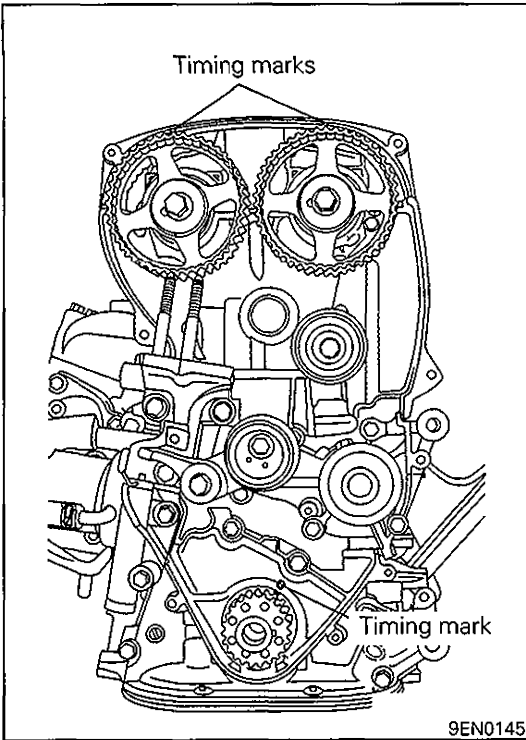

### ▶C▶ INSTALLATION OF TIMING BELT

- (1) Make sure that the auto-tensioner is installed properly. (Refer to ▶B▶.)
- (2) Align the timing mark on each sprocket with the corresponding mark on the timing belt.
- (3) Turn the crankshaft sprocket one half the tooth width counterclockwise.

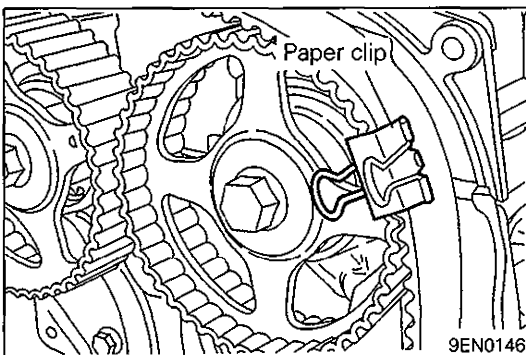

- (4) Fit the timing belt to the intake camshaft sprocket and secure with a paper clip at the illustrated position.

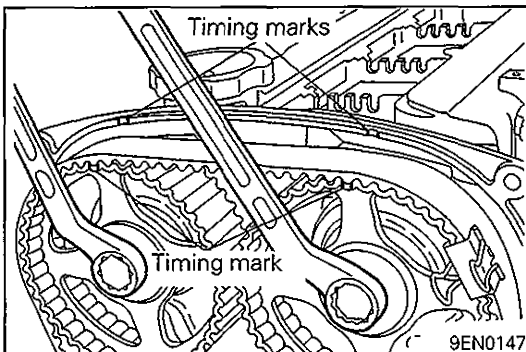

- (5) Use two wrenches to fit the timing belt to the exhaust sprocket while aligning the timing marks.

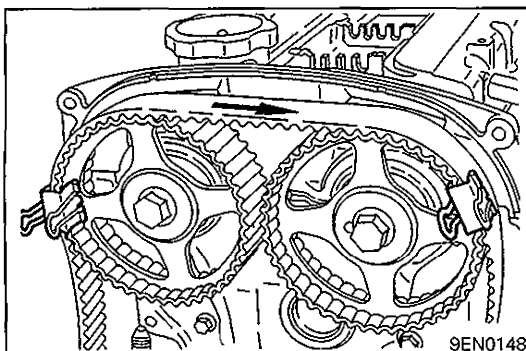

- (6) Secure the timing belt with a paper clip at the illustrated position.

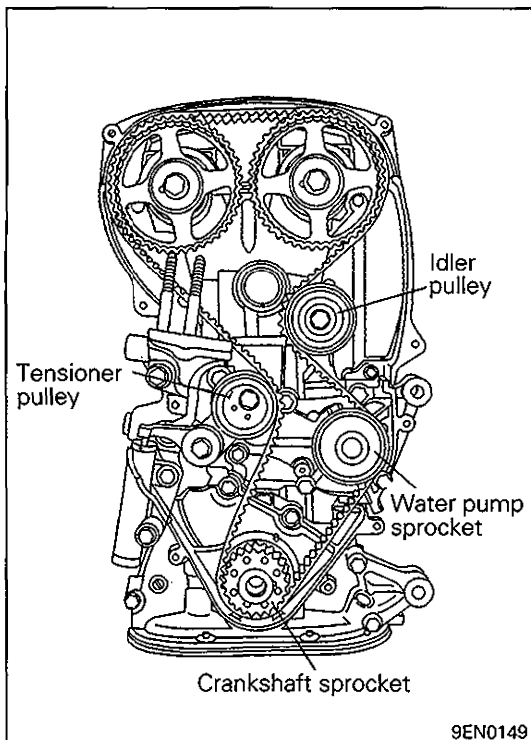

- (7) Fit the belt to the idler pulley water pump sprocket and tensioner pulley in that order.

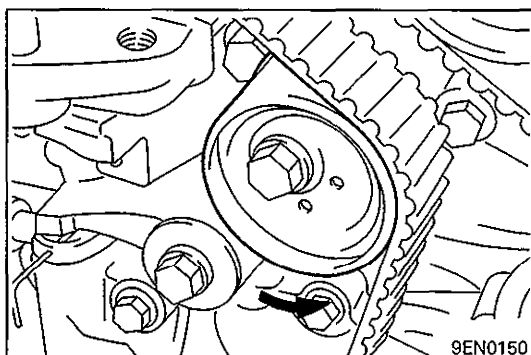

- (8) Raise the tensioner pulley in the direction of an arrow and tighten the tensioner pulley bolt.

(9) Remove the two paper clips.

(10) Make sure that all timing marks are in alignment.

(11) Give a 1/4 counterclockwise turn to the crankshaft. Then turn the crankshaft clockwise to align the timing marks again.

(12) Install the special tool and a torque wrench to the tensioner pulley.

(13) Using torque wrench, torque to 2.6 Nm (0.26 kgm, 1.9 ft.lbs.).

(14) While holding the tensioner pulley to prevent it from turning, tighten the center bolt to the specified torque.

(15) Give two clockwise turns to the crankshaft and leave as it is for approx. 15 minutes.

(16) Check if the Allen wrench inserted during installation of the auto-tensioner can be pulled out lightly.

If it can be pulled out lightly, the belt is properly tensioned. Therefore, pull out the wrench. The belt is also properly tensioned if the auto-tensioner projection is of standard value.

**Standard value: 3.8 – 4.5 mm (0.150 – 0.177 in.)**

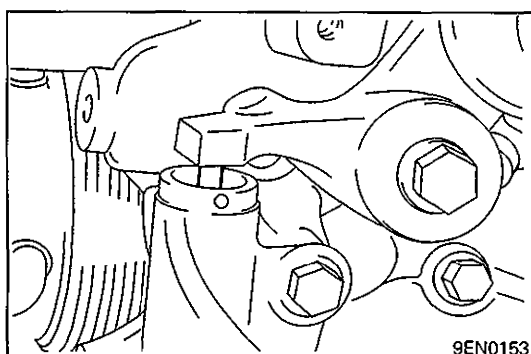
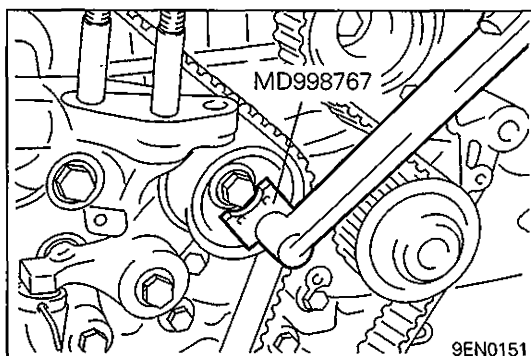

- (17) If the wrench cannot be pulled out lightly, repeat the steps (12) through (15) to obtain appropriate belt tension.

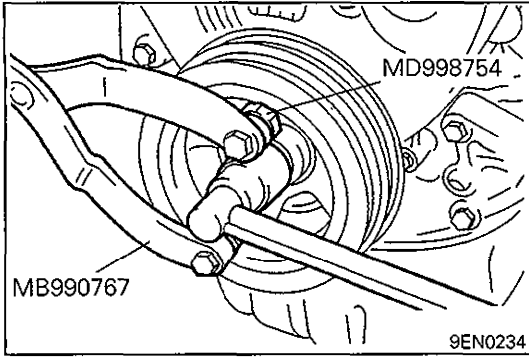

**◆D◆ INSTALLATION OF CRANKSHAFT BOLT**

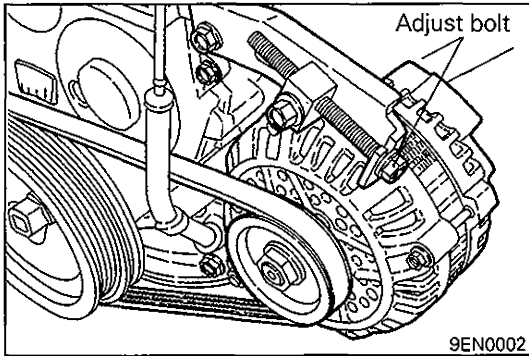

**◆E◆ ADJUSTMENT OF DRIVE BELT TENSION**

(1) Adjust belt deflection with adjusting bolt to standard value.

**Standard value:**

<b>New belt</b>	<b>7.0 – 8.5 mm (0.28 – 0.33 in.)</b>
<b>Used belt</b>	<b>9.5 mm (0.37 in.)</b>

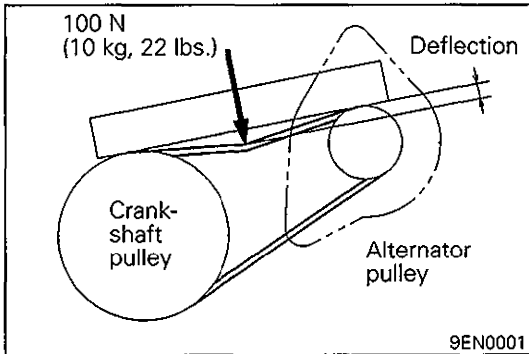

(2) Or using tension gauge, adjust tension to standard value.

**Standard value:**

<b>New belt</b>	<b>500 – 700 N (50 – 70 kg, 110 – 154 lbs.)</b>
<b>Used belt</b>	<b>400 N (40 kg, 88 lbs.)</b>

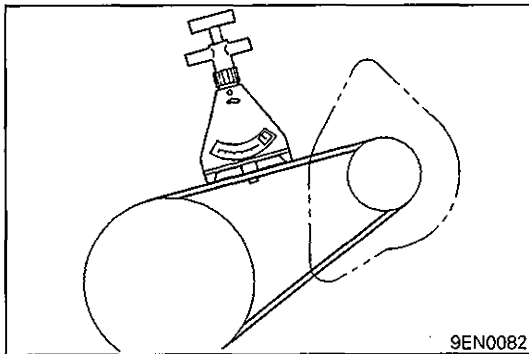

(3) Tighten lock bolt to the specified torque.

(4) Tighten nut for pivot bolt to the specified torque.

## 7. FUEL AND EMISSION CONTROL SYSTEM (SINGLE CAMSHAFT ENGINE)

### REMOVAL AND INSTALLATION – MULTIPOINT FUEL INJECTION

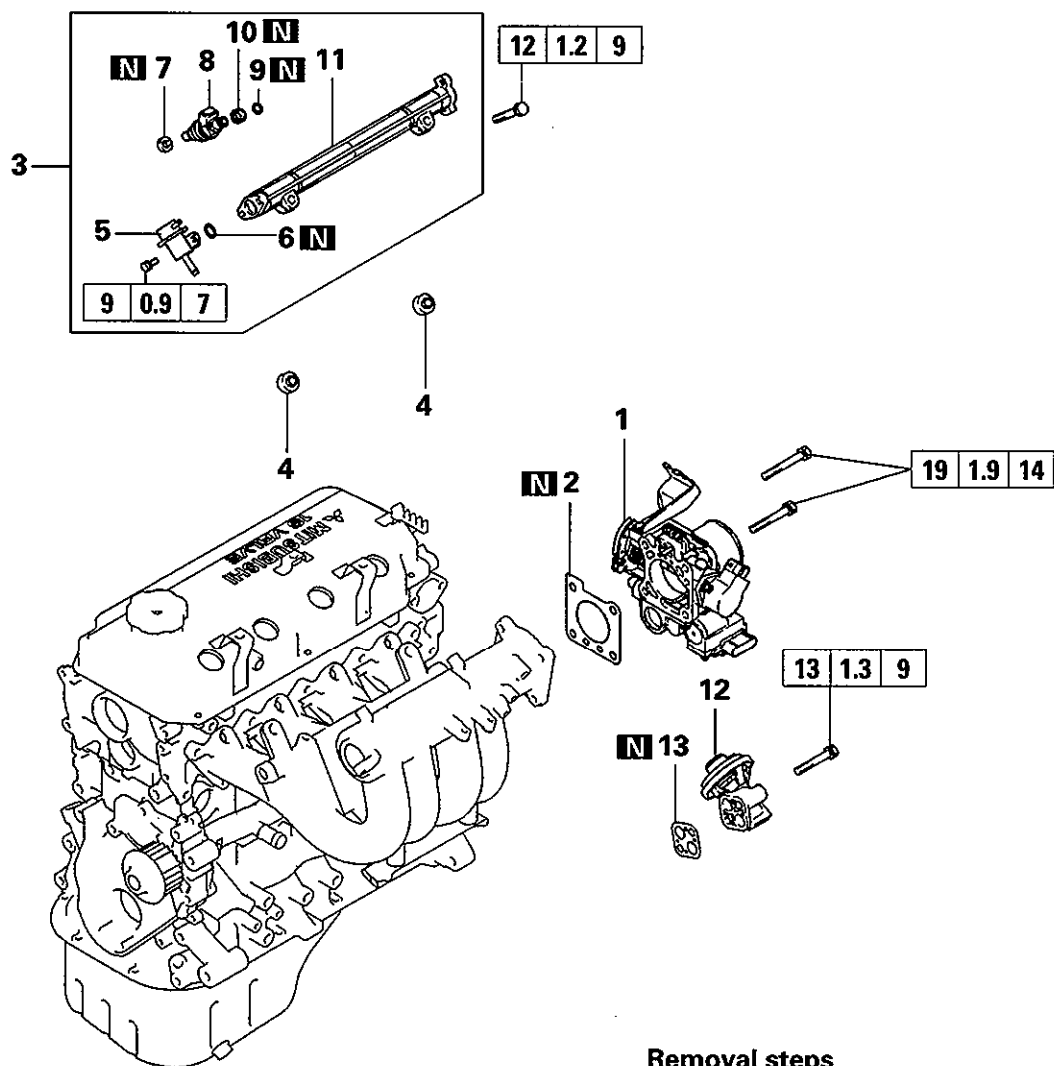

#### Removal steps

1. Throttle body
2. Gasket
3. Delivery pipe and injector
4. Insulator
- ▶B▶ 5. Fuel pressure regulator
6. O-ring
7. Insulator
- ▶A▶ 8. Injector
9. O-ring
10. Grommet
11. Delivery pipe
12. EGR valve
13. Gasket



REMOVAL AND INSTALLATION - CARBURETOR (FRONT WHEEL DRIVE VEHICLE)

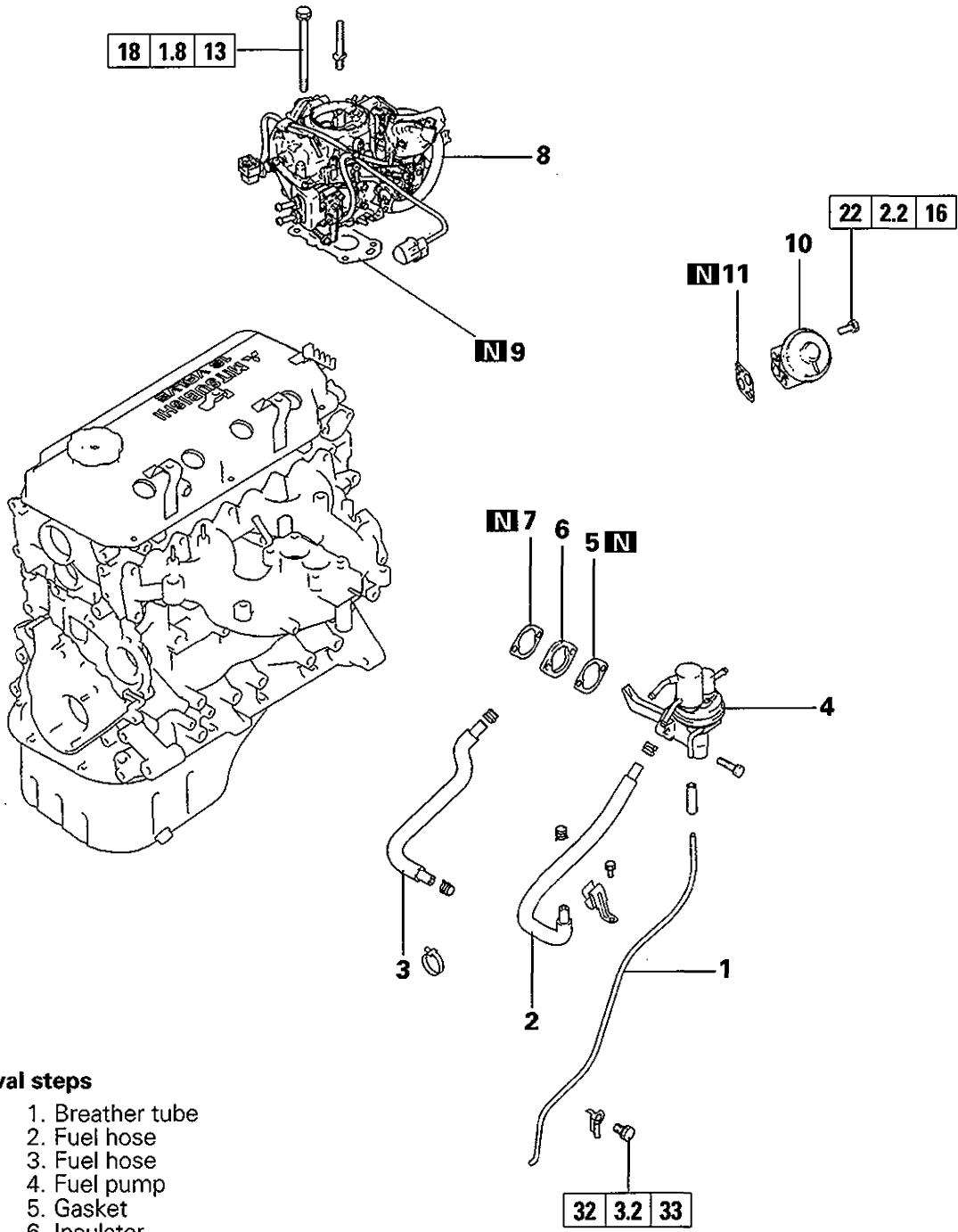

**Removal steps**

1. Breather tube
2. Fuel hose
3. Fuel hose
4. Fuel pump
5. Gasket
6. Insulator
7. Gasket
8. Carburetor
9. Gasket
10. EGR valve
11. Gasket

436

## REMOVAL AND INSTALLATION — CARBURETOR (REAR WHEEL DRIVE VEHICLE)

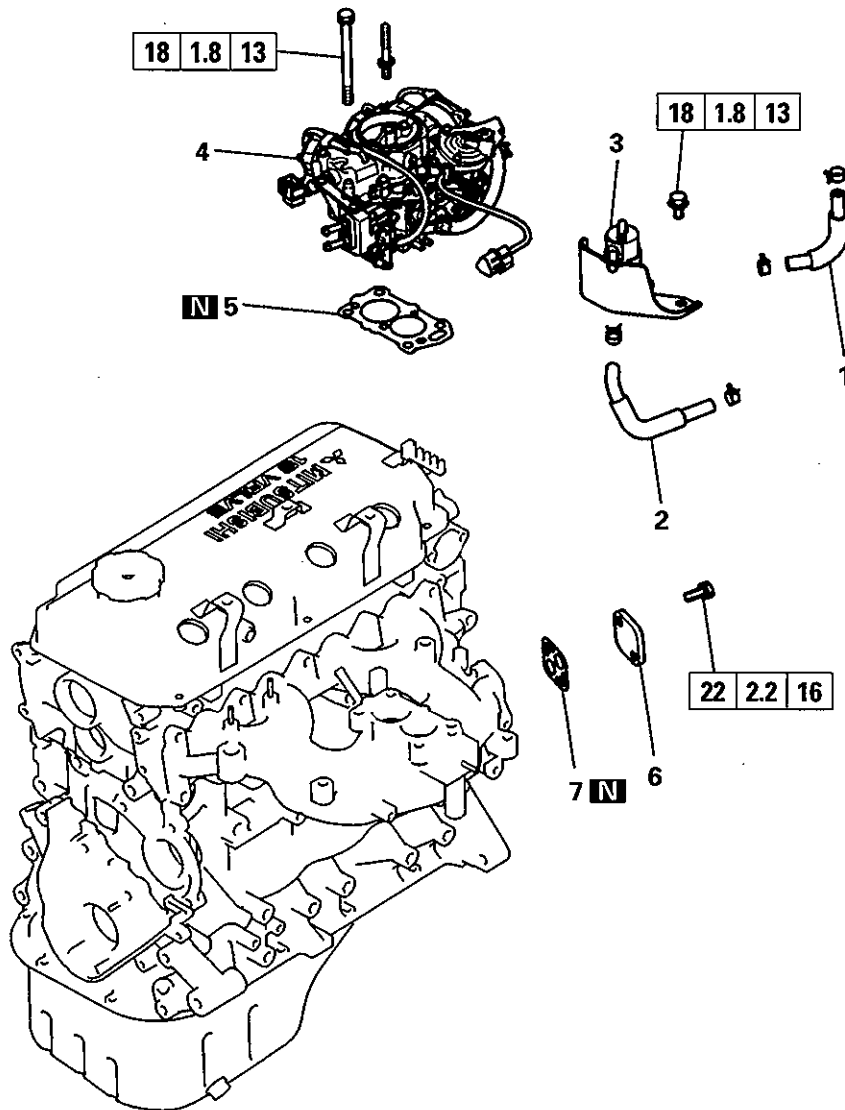
**Removal steps**

1. Fuel hose
2. Fuel hose
3. Fuel vapor separator
4. Carburetor
5. Gasket
6. Cover
7. Gasket

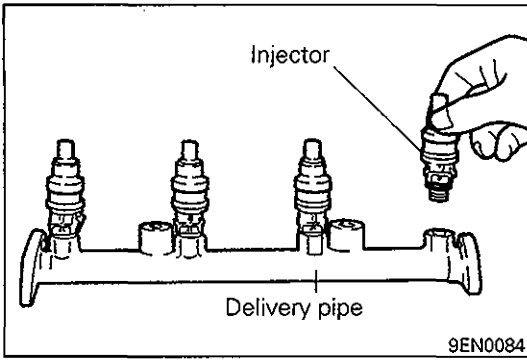

## SERVICE POINTS OF INSTALLATION

### ◆A◆ INSTALLATION OF INJECTORS

- (1) Before installing an injector, the rubber O-ring must be lubricated with a drop of clean engine oil to aid in installation.
- (2) Install injector top end into delivery pipe. Be careful not to damage O-ring during installation.

### ◆B◆ INSTALLATION OF FUEL PRESSURE REGULATOR

- (1) Before installing pressure regulator, the O-ring must be lubricated with a drop of clean engine oil to aid in installation.

# 8. FUEL AND EMISSION CONTROL SYSTEM (DOUBLE CAMSHAFT ENGINE)

## REMOVAL AND INSTALLATION

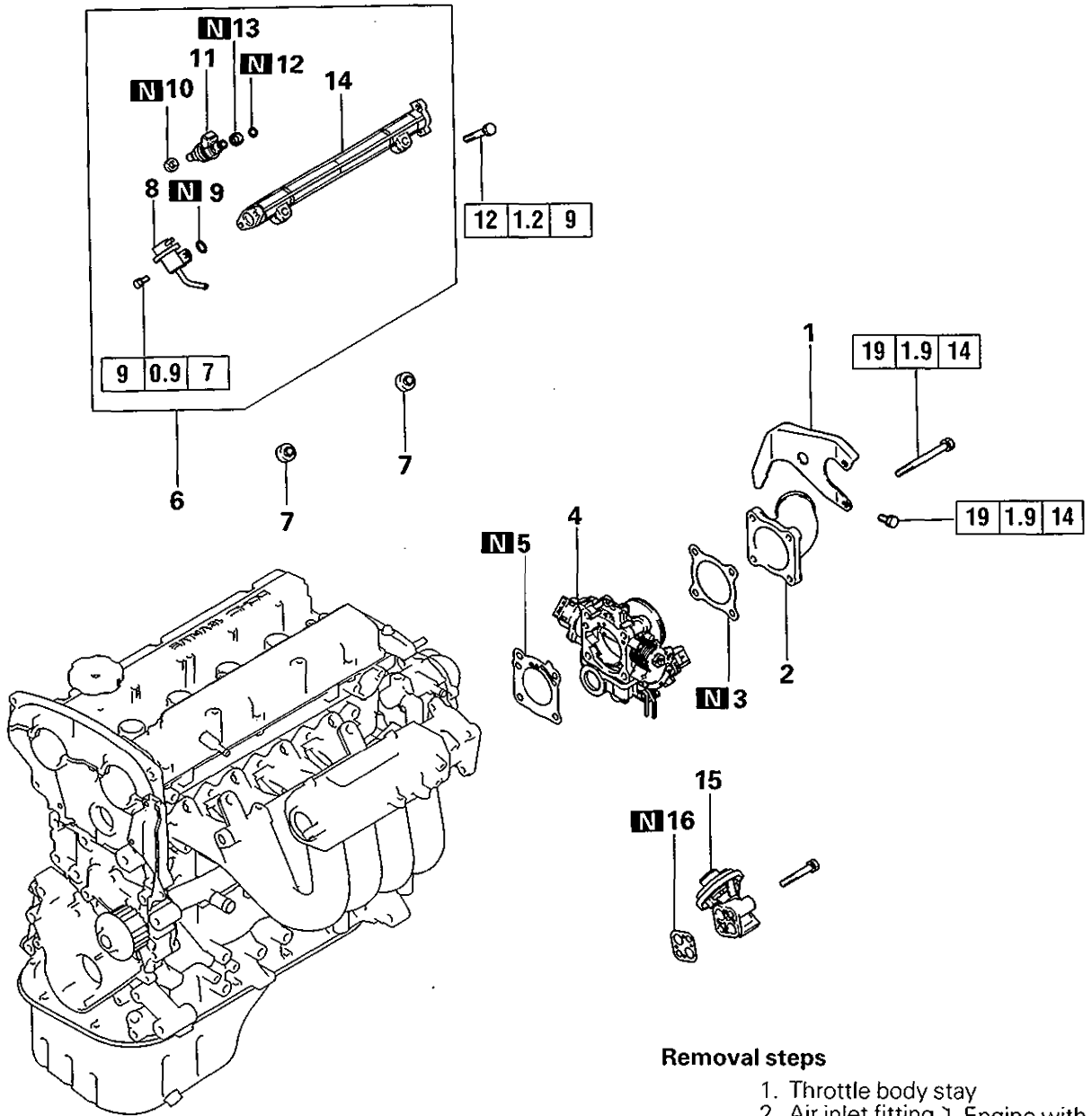

### Removal steps

1. Throttle body stay
2. Air inlet fitting } Engine with
3. Gasket } turbocharger
4. Throttle body
5. Gasket
6. Delivery pipe and injector
7. Insulator
- ▶B▶ 8. Fuel pressure regulator
9. O-ring
- ▶A▶ 10. Insulator
11. Injector
12. O-ring
13. Grommet
14. Delivery pipe
15. EGR valve (4G93)
16. Gasket (4G93)

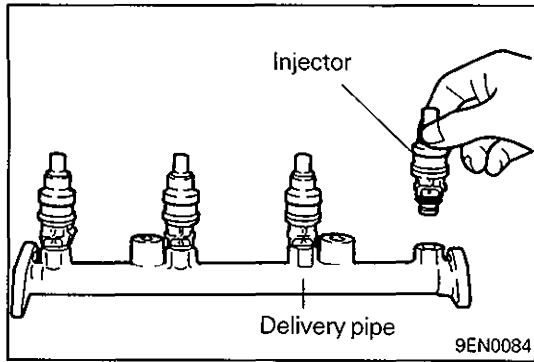

## SERVICE POINTS OF INSTALLATION

### ▶A▶ INSTALLATION OF INJECTORS

- (1) Before installing an injector, the rubber O-ring must be lubricated with a drop of clean engine oil to aid in installation.
- (2) Install injector top end into delivery pipe. Be careful not to damage O-ring during installation.

### ▶B▶ INSTALLATION OF FUEL PRESSURE REGULATOR

- (1) Before installing pressure regulator, the O-ring must be lubricated with a drop of clean engine oil to aid in installation.

# 9. INTAKE MANIFOLD AND WATER PUMP (SINGLE CAMSHAFT ENGINE)

## REMOVAL AND INSTALLATION – MULTIPOINT FUEL INJECTION

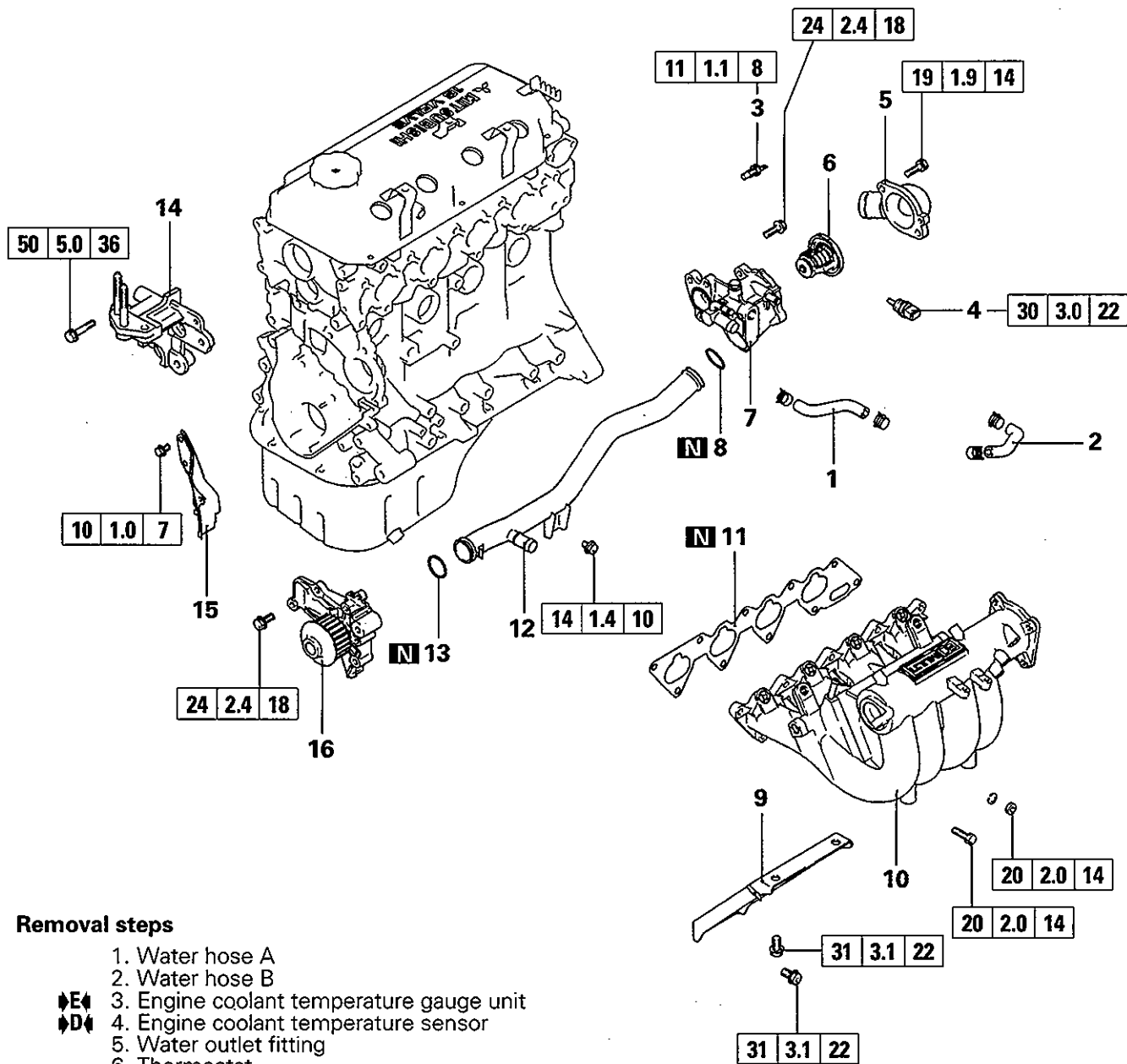

### Removal steps

1. Water hose A
2. Water hose B
- ▶E▶ 3. Engine coolant temperature gauge unit
- ▶D▶ 4. Engine coolant temperature sensor
5. Water outlet fitting
6. Thermostat
- ▶C▶ 7. Thermostat housing
- ▶B▶ 8. O-ring
9. Intake manifold stay
10. Intake manifold
11. Gasket
- ▶B▶ 12. Water pipe
- ▶B▶ 13. O-ring
14. Engine support bracket left
15. Timing belt cover
- ▶A▶ 16. Water pump





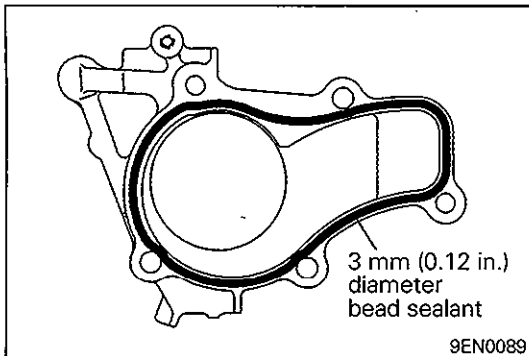

**SERVICE POINTS OF INSTALLATION****▶A▶ APPLICATION OF WATER PUMP**

Specified sealant:

Mitsubishi Genuine Part No. MD970389 or equivalent

**▶B▶ INSTALLATION OF WATER PIPE / O-RING**

(1) Wet the O-ring (with water) to facilitate assembly.

**Caution**

- Keep the O-ring free of oil or grease.
- Secure the water pipe after the thermostat housing has been installed.

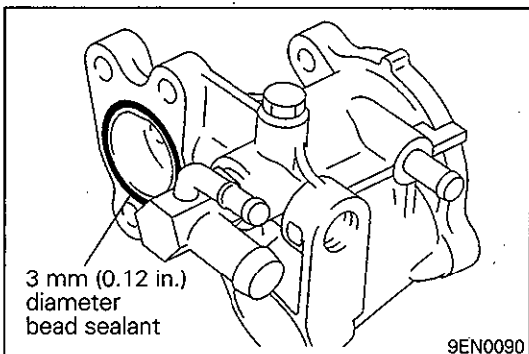
**▶C▶ APPLICATION OF THERMOSTAT HOUSING**

Specified sealant:

Mitsubishi Genuine Part No. MD970389 or equivalent

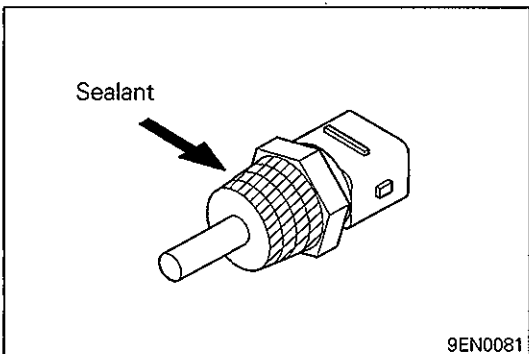
**▶D▶ APPLICATION OF SEALANT TO ENGINE COOLANT TEMPERATURE SENSOR**

Specified sealant:

3M Nut Locking Part No. 4171 or equivalent

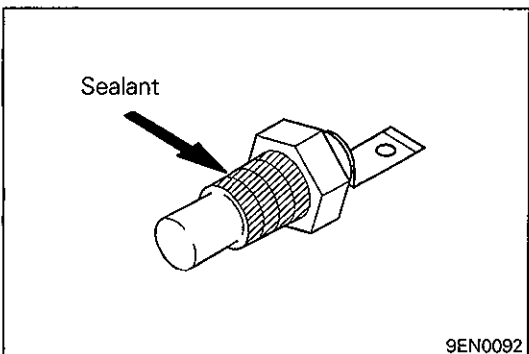
**▶E▶ APPLICATION OF SEALANT TO ENGINE COOLANT TEMPERATURE GAUGE UNIT**

Specified sealant:

3M ATD Part No. 8660 or equivalent

# 10. INTAKE MANIFOLD AND WATER PUMP (DOUBLE CAMSHAFT ENGINE)

## REMOVAL AND INSTALLATION

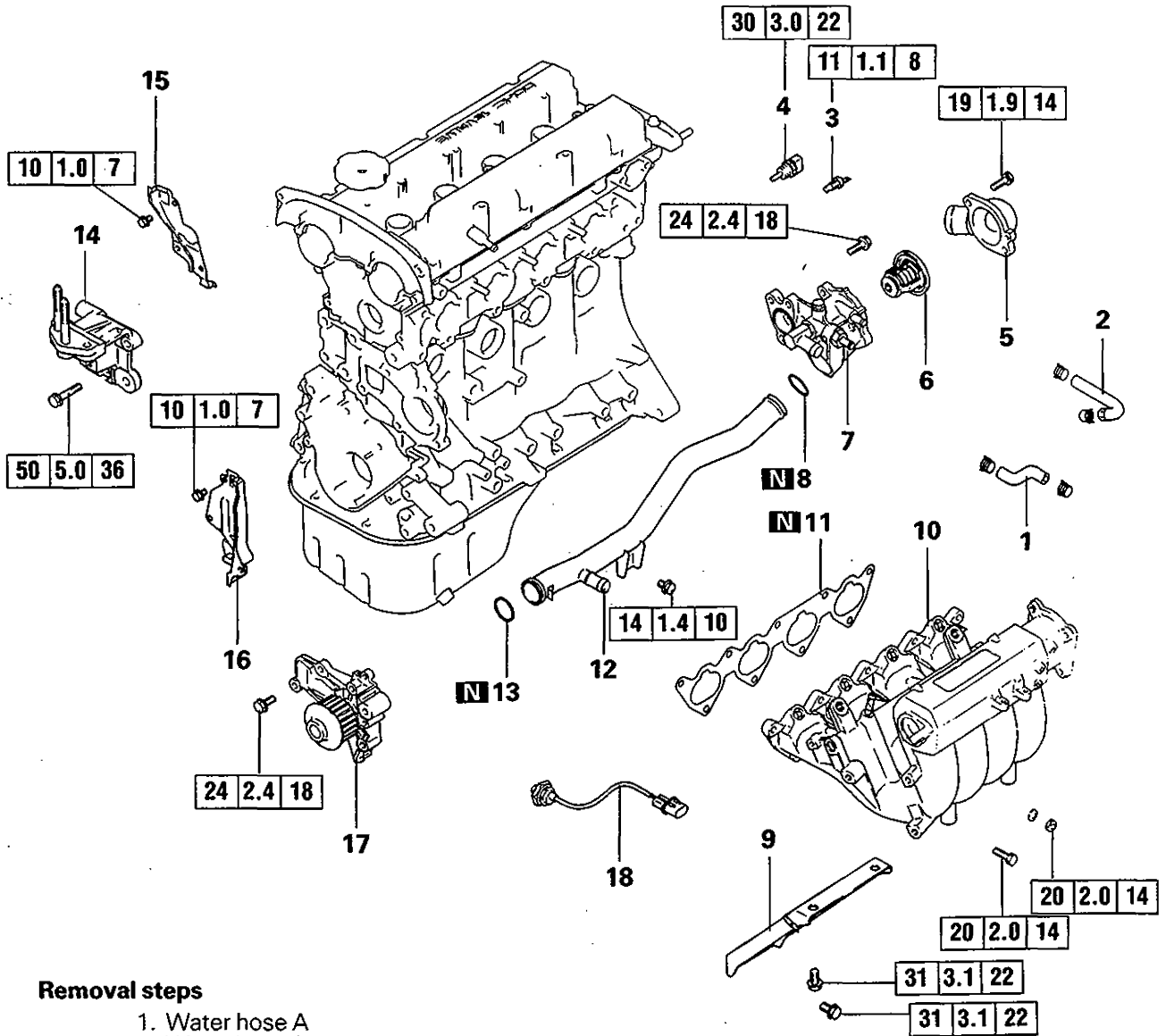

### Removal steps

1. Water hose A
2. Water hose B
- ◆E◆ 3. Engine coolant temperature gauge unit
- ◆D◆ 4. Engine coolant temperature sensor
5. Water outlet fitting
6. Thermostat
- ◆C◆ 7. Thermostat housing
- ◆B◆ 8. O-ring
9. Intake manifold stay
10. Intake manifold
11. Gasket
- ◆B◆ 12. Water pipe
- ◆B◆ 13. O-ring
14. Engine support bracket left
15. Timing belt cover
16. Timing belt cover
- ◆A◆ 17. Water pump
18. Detonation sensor

575

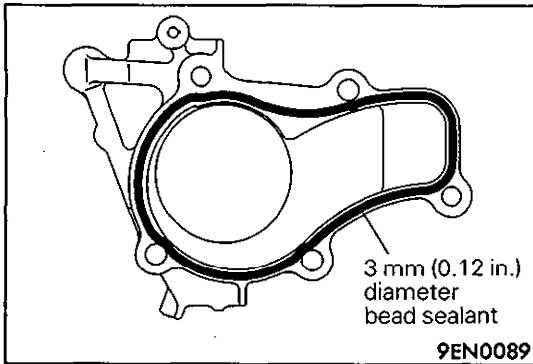

## SERVICE POINTS OF INSTALLATION

### ◆A◆ APPLICATION OF WATER PUMP

Specified sealant:

Mitsubishi Genuine Part No. MD970389 or equivalent

### ◆B◆ INSTALLATION OF WATER PIPE / O-RING

(1) Wet the O-ring (with water) to facilitate assembly.

Caution

- Keep the O-ring free of oil or grease.
- Secure the water pipe after the thermostat housing has been installed.

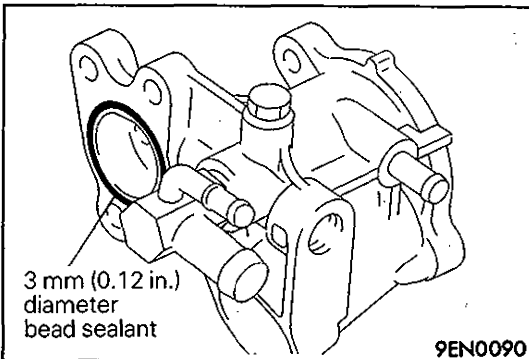

### ◆C◆ APPLICATION OF THERMOSTAT HOUSING

Specified sealant:

Mitsubishi Genuine Part No. MD970389 or equivalent

### ◆D◆ APPLICATION OF SEALANT TO ENGINE COOLANT TEMPERATURE SENSOR

Specified sealant:

3M Nut Locking Part No. 4171 or equivalent

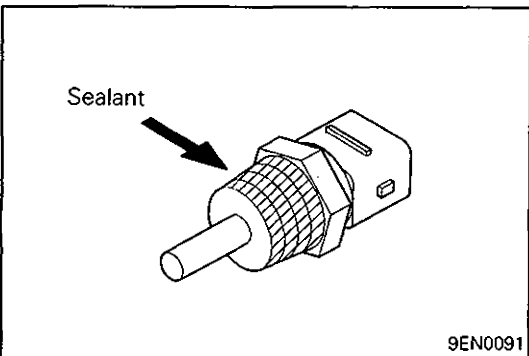

### ◆E◆ APPLICATION OF SEALANT TO ENGINE COOLANT TEMPERATURE GAUGE UNIT

Specified sealant:

3M ATD Part No. 8660 or equivalent

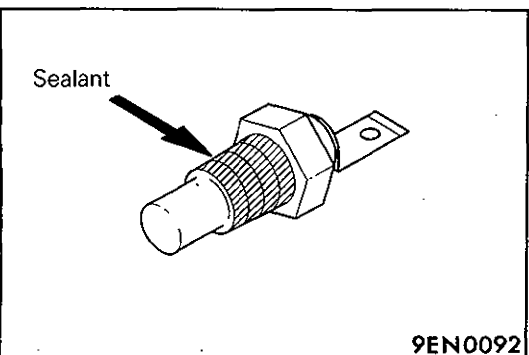

# 11. EXHAUST MANIFOLD

## REMOVAL AND INSTALLATION

(Single Camshaft Engine – For Front Wheel Drive Vehicle)

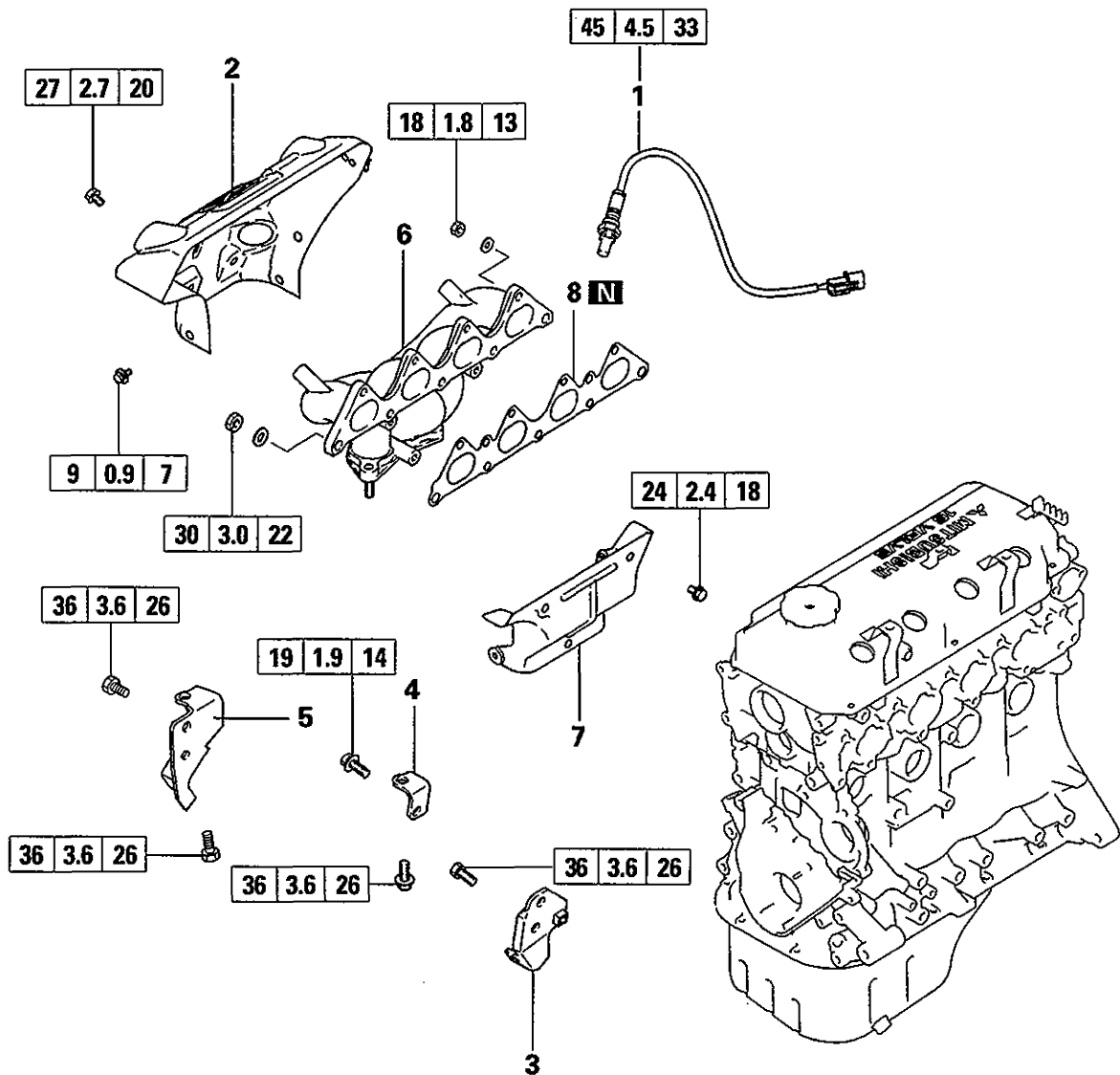

### Removal steps

1. Oxygen sensor – for Europe, HongKong
2. Exhaust manifold cover A
3. Exhaust manifold bracket A (4G92)
4. Exhaust manifold bracket B (4G92)
5. Exhaust manifold bracket (4G93)
6. Exhaust manifold
7. Exhaust manifold cover B – for Europe, HongKong
8. Gasket

## REMOVAL AND INSTALLATION

(Single Camshaft Engine – For Rear Wheel Drive Vehicle)

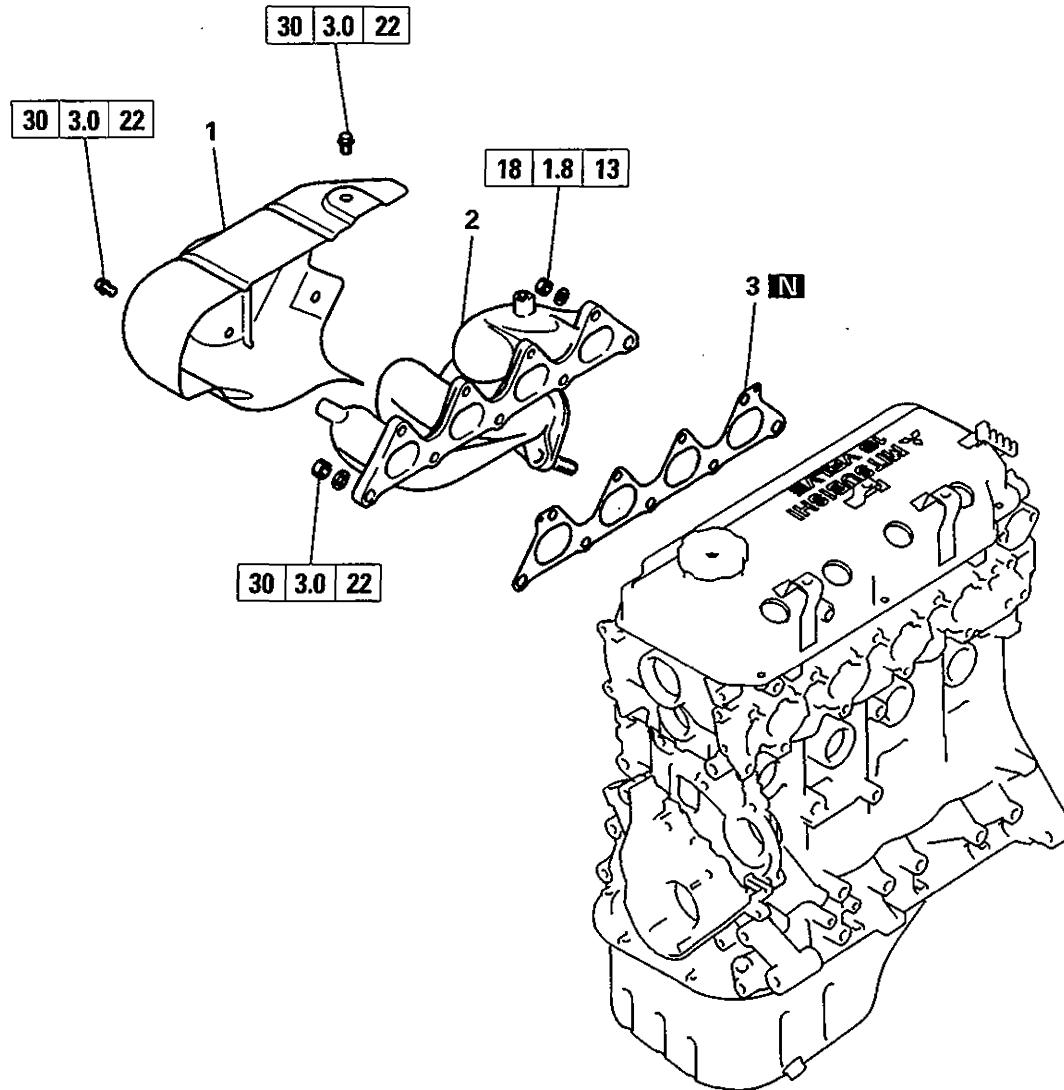
**Removal steps**

1. Exhaust manifold cover
2. Exhaust manifold
3. Gasket

## REMOVAL AND INSTALLATION

(Double Camshaft Engine without Turbocharger)

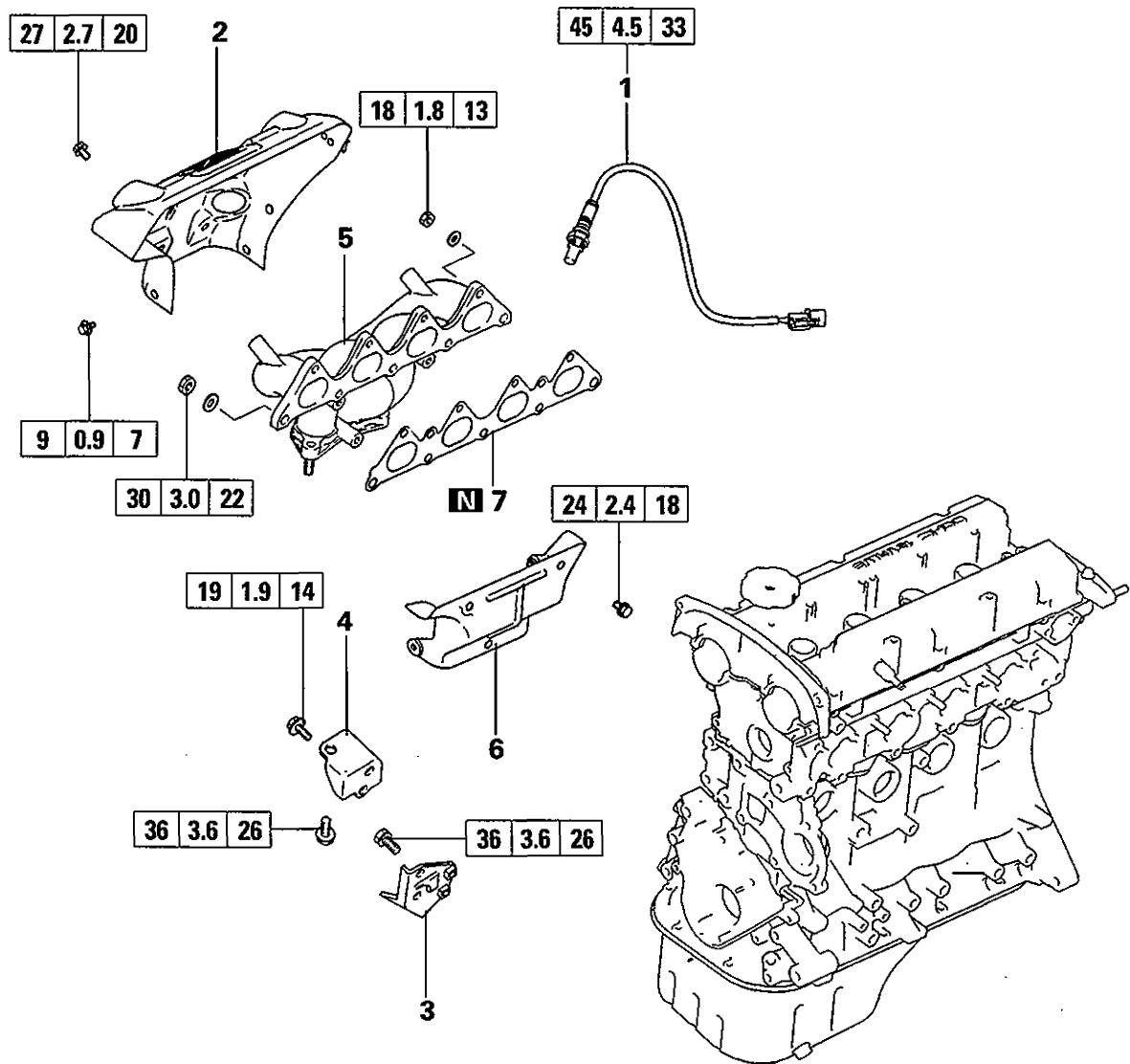

## Removal steps

1. Oxygen sensor – for Europe, HongKong
2. Exhaust manifold cover A
3. Exhaust manifold bracket A
4. Exhaust manifold bracket B
5. Exhaust manifold
6. Exhaust manifold cover B – for Europe, HongKong
7. Gasket

REMOVAL AND INSTALLATION

(Double Camshaft Engine with Turbocharger)

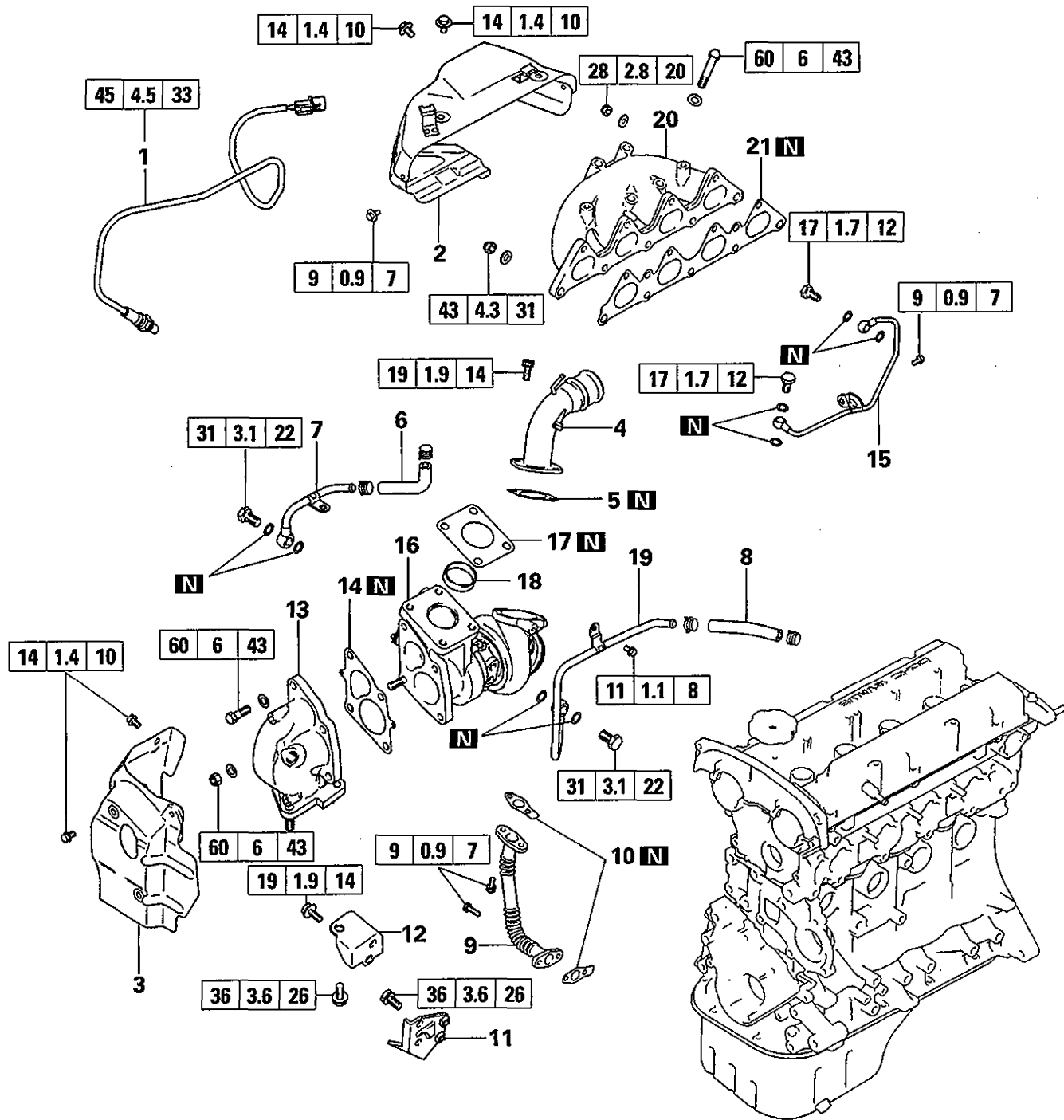

Removal steps

- |                          |                               |                      |
|--------------------------|-------------------------------|----------------------|
| 1. Oxygen sensor         | 8. Water hose                 | 15. Oil pipe         |
| 2. Heat protector A      | 9. Oil return pipe            | 16. Turbocharger     |
| 3. Heat protector B      | 10. Gasket                    | ▶▶ 17. Gasket        |
| ▶▶ 4. Air outlet fitting | 11. Exhaust fitting bracket A | 18. Ring             |
| ▶▶ 5. Gasket             | 12. Exhaust fitting bracket B | 19. Water pipe       |
| 6. Water hose            | 13. Exhaust fitting           | 20. Exhaust manifold |
| 7. Water pipe            | 14. Gasket                    | 21. Gasket           |

**SERVICE POINTS OF INSTALLATION****▶A◀ INSTALLATION OF GASKET**

- (1) Install the gasket with its surface, having identification letters, directed toward the exhaust manifold.

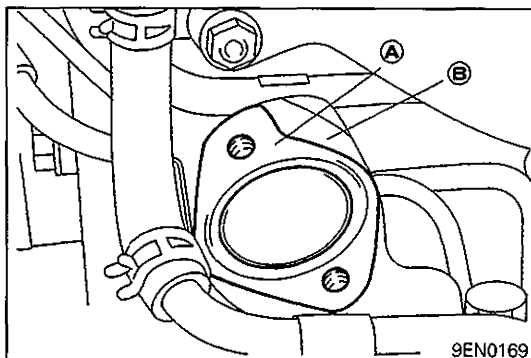
**▶B◀ INSTALLATION OF GASKET**

- (1) Install the gasket with its portion ① (see the illustration) located toward the portion ② (see the illustration) of the air outlet flange.



---

NOTES

# 12. TURBOCHARGER

## DISASSEMBLY AND REASSEMBLY

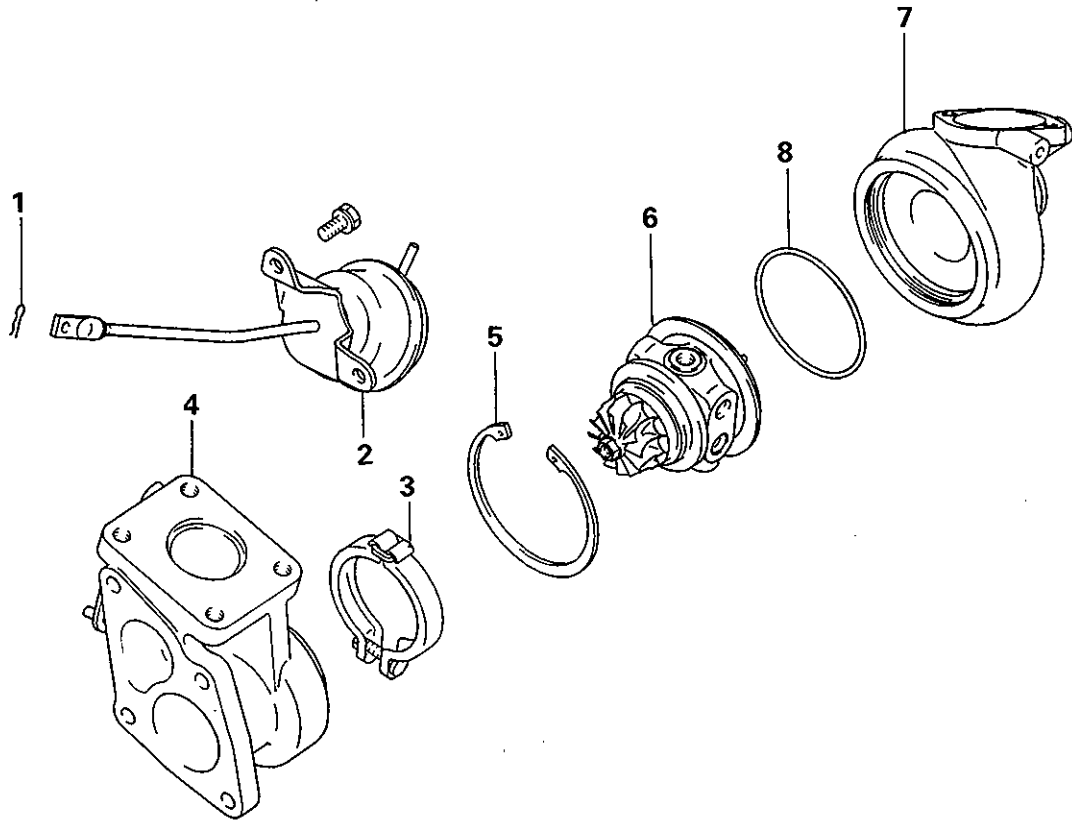

### Disassembly steps

- 1. Snap pin
- 2. Waste gate actuator
- ▶E◀ 3. Coupling
- ▶D◀ 4. Turbine housing
- ◁A▷ ▶C◀ 5. Snap ring
- ◁B▷ ▶B◀ 6. Turbine wheel assembly
- 7. Compressor cover
- ▶A◀ 8. O-ring

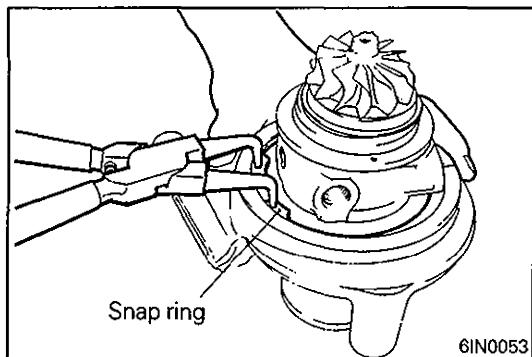

## SERVICE POINTS OF DISASSEMBLY

### ◊A◊ REMOVAL OF SNAP RING

- (1) Lay the unit with the compressor cover side facing down and using snap ring pliers, remove the compressor cover attaching snap ring.

#### Caution

- When removing the snap ring, hold it with fingers to prevent it from springing away.

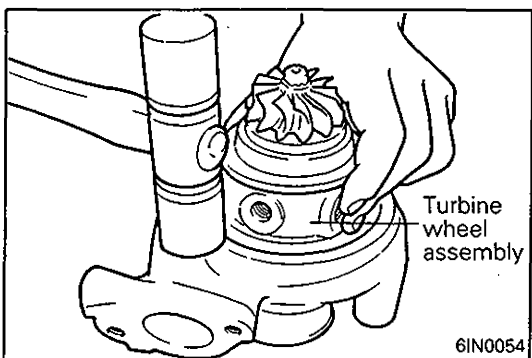

### ◊B◊ REMOVAL OF TURBINE WHEEL ASSEMBLY

- (1) Remove the turbine wheel assembly, striking the circumference of the compressor cover with a plastic hammer.

The turbine wheel assembly may be a little hard to remove due to an O-ring put on the outer circumference.

## CLEANING

- (1) Use a clean cleaning oil commercially available. Do not use corrosive cleaning oils as they could damage to some parts.
- (2) Use a plastic scraper or hard brush to clean aluminum parts.

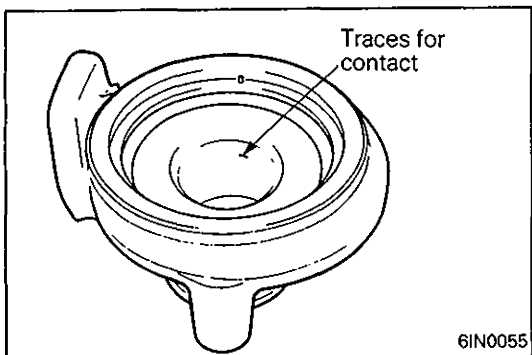

## INSPECTION

### TURBINE HOUSING

- (1) Check the housing for traces of contact with the turbine wheel, cracks due to overheating, pitching, deformation and other damage. Replace with a new turbine housing if cracked.
- (2) Operate the waste gate valve lever manually to check that the gate can be opened and closed smoothly.

### COMPRESSOR COVER

- (1) Check the compressor cover for traces of contact with the compressor wheel and other damage.

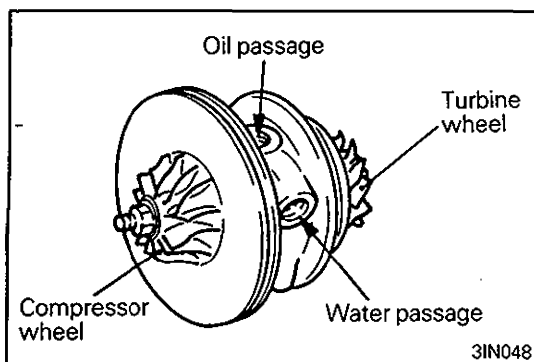
**TURBINE WHEEL ASSEMBLY**

- (1) Check the turbine and compressor wheel blades for bend, burr, damage, corrosion and traces of contact on the back side and replace if defective.
- (2) Check the oil passage of the turbine wheel assembly for deposit and clogging.
- (3) In the case of water cooled type, check also the water passage for deposit and clogging.
- (4) Check the turbine wheel and compressor wheel for light and smooth turning.

**OIL PIPE/OIL RETURN PIPE**

- (1) Correct or replace the oil pipe and oil return pipe if clogged, collapsed, deformed or otherwise damaged.

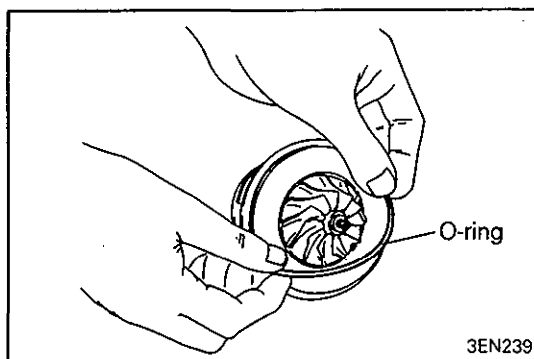
**SERVICE POINTS OF REASSEMBLY****▶A▶ INSTALLATION OF O-RING**

- (1) Apply a light coat of engine oil to a new O-ring and fit in the turbine wheel assembly groove.

**Caution**

- When installing the O-ring, use care not to damage it. A damaged O-ring causes oil leaks.

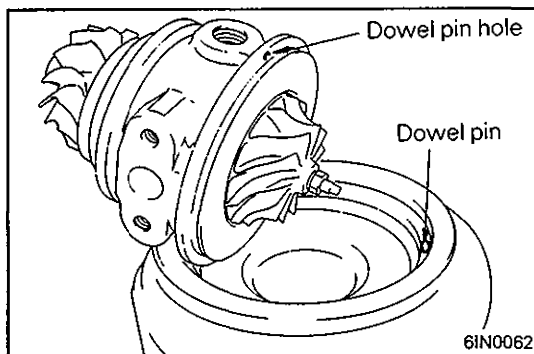
**▶B▶ INSTALLATION OF TURBINE WHEEL ASSEMBLY**

- (1) Apply a light coat of engine oil to the periphery of the O-ring.
- (2) Install the turbine wheel assembly to the compressor cover in relation to the dowel pin.

**Caution**

- Use care not to damage the blades of turbine wheel and compressor wheel.

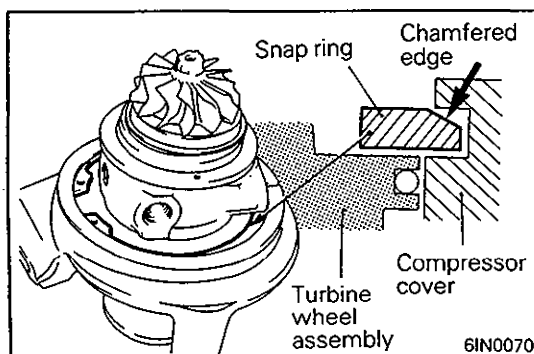
**▶C▶ INSTALLATION OF SNAP RING**

- (1) Lay the assembly with the compressor cover facing down and fit the snap ring.

**Caution**

- Fit the snap ring with its chamfered side facing up.

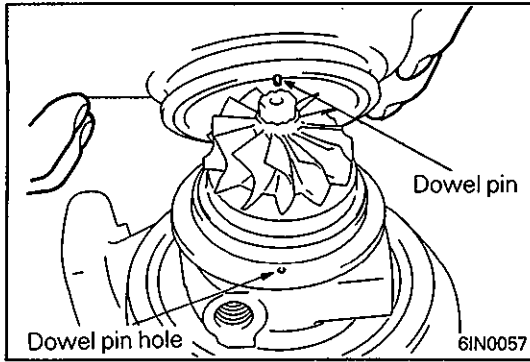

### ◆D◆ INSTALLATION OF TURBINE HOUSING

- (1) Install the turbine housing in relation to the dowel pin.

#### Caution

- Use care not damage the blades of turbine wheel.

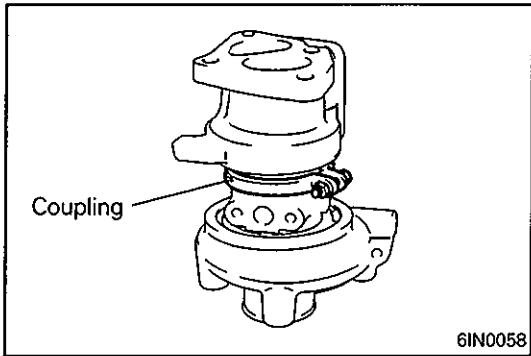

### ◆E◆ INSTALLATION OF COUPLING

- (1) Install the coupling and tighten to specified torque.

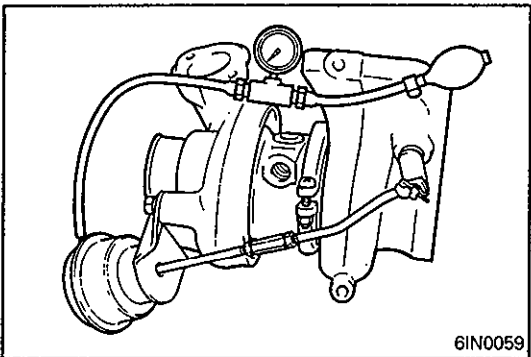

### ◆F◆ INSPECTION OF WASTE GATE ACTUATOR OPERATION

- (1) Using a tester, apply a pressure of approx. 85 kPa (0.87 kg/cm<sup>2</sup>, 12.4 psi) to the actuator and make sure that the rod moves.

#### Caution

- Do not apply a pressure of more than 109 kPa (1.11 kg/cm<sup>2</sup>, 15.8 psi) to the actuator. Otherwise, diaphragm may be damaged.  
Never attempt to adjust the waste gate valve.

## 13. ROCKER ARMS AND CAMSHAFT (SINGLE CAMSHAFT ENGINE)

## REMOVAL AND INSTALLATION

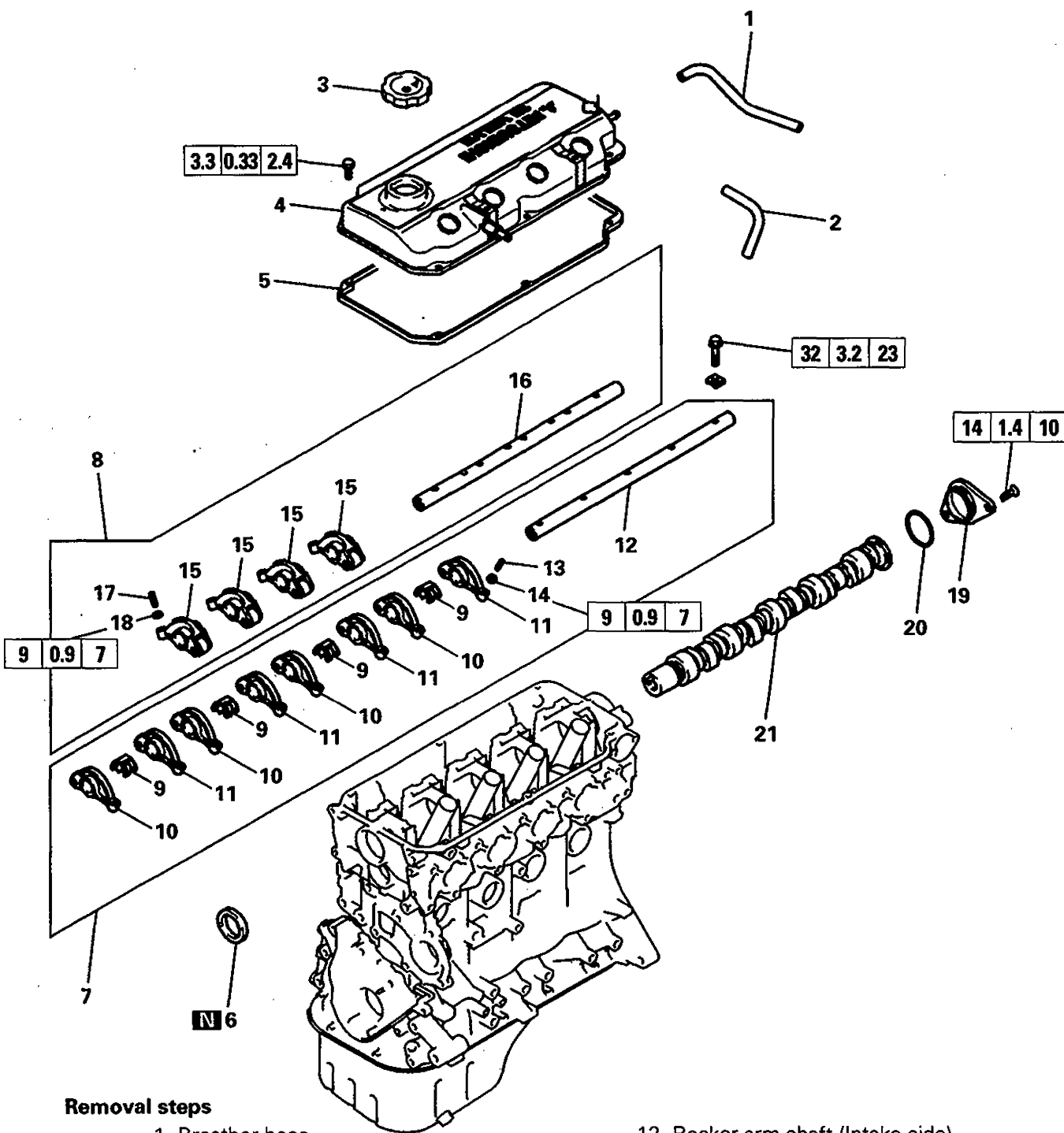

## Removal steps

- |     |                                     |  |
|-----|-------------------------------------|--|
|     | 1. Breather hose                    | 12. Rocker arm shaft (Intake side)         |
|     | 2. P.C.V. hose                      | 13. Adjusting screw                        |
|     | 3. Oil filler cap                   | 14. Nut                                    |
|     | 4. Rocker cover                     | 15. Rocker arm C                           |
|     | 5. Rocker cover gasket              | 16. Rocker arm shaft (Exhaust side)        |
| ▶B▶ | 6. Oil seal                         | 17. Adjusting screw                        |
| ▶A▶ | 7. Rocker arms and rocker arm shaft | 18. Nut                                    |
|     | 8. Rocker arms and rocker arm shaft | 19. Thrust case (Rear wheel drive vehicle) |
| ▶A▶ | 9. Rocker shaft spring              | 20. O-ring (Rear wheel drive vehicle)      |
|     | 10. Rocker arm A                    | 21. Camshaft                               |
|     | 11. Rocker arm B                    |  |

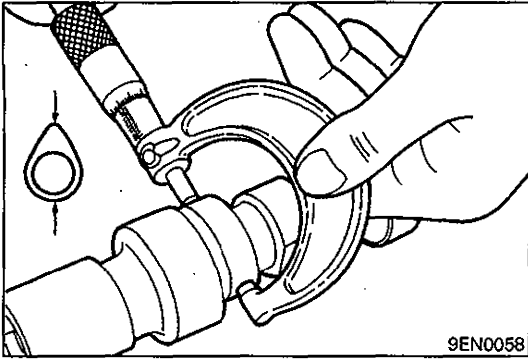

## INSPECTION CAMSHAFT

(1) Measure the cam height.

mm (in.)

Identification mark	Standard value		Limit
	INTAKE	EXHAUST	
1	37.78 (1.4874)	37.28 (1.4677)	
	38.09 (1.4996)	37.59 (1.4799)	
2	37.97 (1.4949)	37.47 (1.4752)	
	38.09 (1.4996)	37.59 (1.4799)	
3	37.78 (1.4874)	37.28 (1.4677)	
	37.83 (1.4894)	37.33 (1.4697)	
4	37.53 (1.4776)	37.03 (1.4579)	
	37.32 (1.4693)	36.82 (1.4496)	
5	37.53 (1.4776)	37.03 (1.4579)	
	38.09 (1.4996)	37.59 (1.4799)	
7	37.16 (1.4630)	36.66 (1.4433)	
	36.93 (1.4539)	36.43 (1.4342)	
8	37.03 (1.4579)	36.53 (1.4382)	
	36.99 (1.4563)	36.49 (1.4366)	
10	37.53 (1.4776)	37.03 (1.4579)	
	37.64 (1.4819)	37.14 (1.4622)	

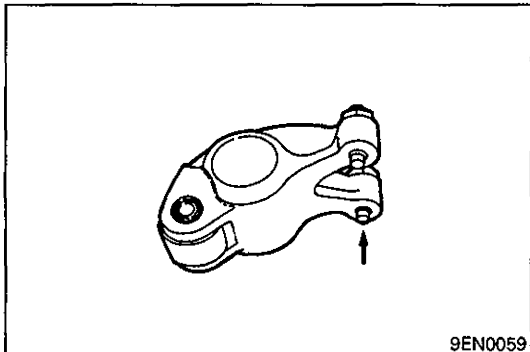

## ROCKER ARM

- Check the roller surface. If any dents, damage or seizure is evident, replace the rocker arm.
- Check rotation of the roller. If it does not rotate smoothly or if looseness is evident, replace the rocker arm.
- Check the inside diameter. If damage or seizure is evident, replace the rocker arm.
- Check the screw end for wear. If considerable wear is evident, replace the adjusting screw.

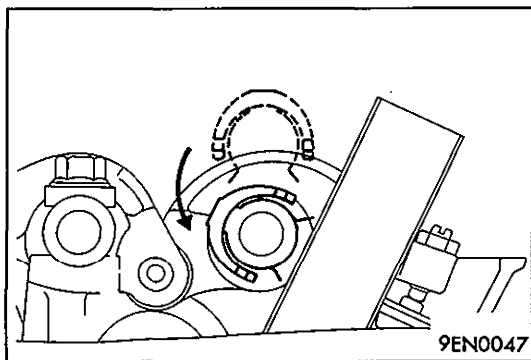
**SERVICE POINTS OF INSTALLATION****◆A◆ INSTALLATION OF ROCKER SHAFT SPRING /  
ROCKER ARMS AND ROCKER ARM SHAFT**

- (1) Temporarily tighten the rocker shaft with the bolt so that all rocker arms on the inlet valve side do not push the valves.
- (2) Fit the rocker shaft spring from the above and position it so that it is right angles to the plug guide.
- (3) Tighten the rocker arm shaft bolt to specification.

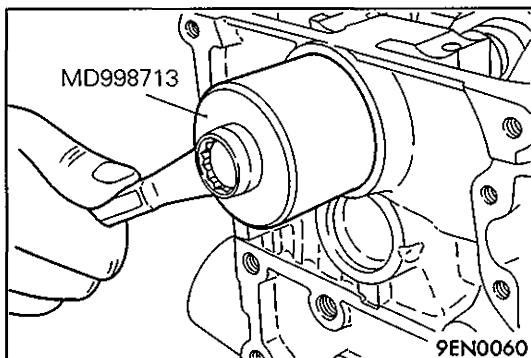
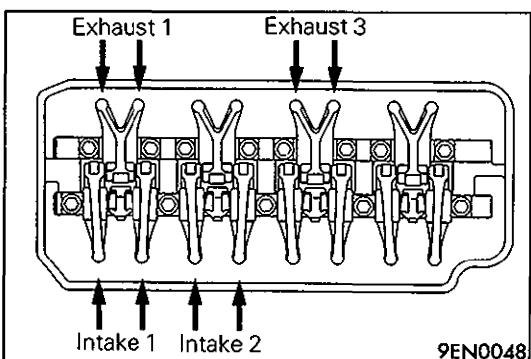
**◆B◆ INSTALLATION OF OIL SEAL****VALVE CLEARANCE ADJUSTMENT**

- (1) Position the No. 1 cylinder at top dead center on the compression stroke.
- (2) Adjust the valve clearance at the points shown in the illustration.

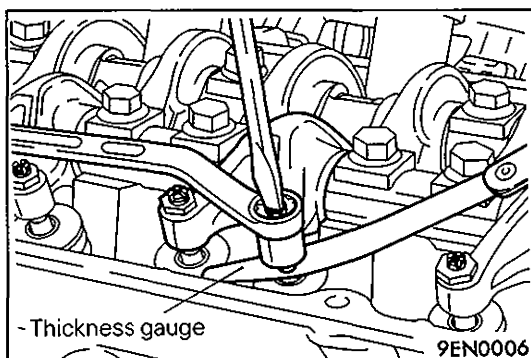

- (3) Loosen the adjusting screw locknut.
- (4) Using a feeler gauge, adjust the valve clearance by turning the adjusting screw.

**Standard value: on cold engine**

<b>Intake</b>	<b>0.09 mm (0.0035 in.)</b>
<b>Exhaust</b>	<b>0.20 mm (0.0079 in.)</b>

- (5) While holding the adjusting screw with a screwdriver, tighten the lock nut.

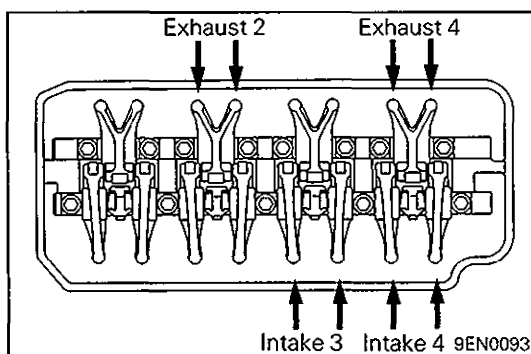

- (6) Rotate clockwise the crankshaft one complete turn.
- (7) Adjust the valve clearance at points as shown in the illustration.
- (8) Repeat steps (3) to (5) to adjust the valve clearance of remaining valves.



---

NOTES

# 14. ROCKER ARMS AND CAMSHAFT (DOUBLE CAMSHAFT ENGINE) REMOVAL AND INSTALLATION

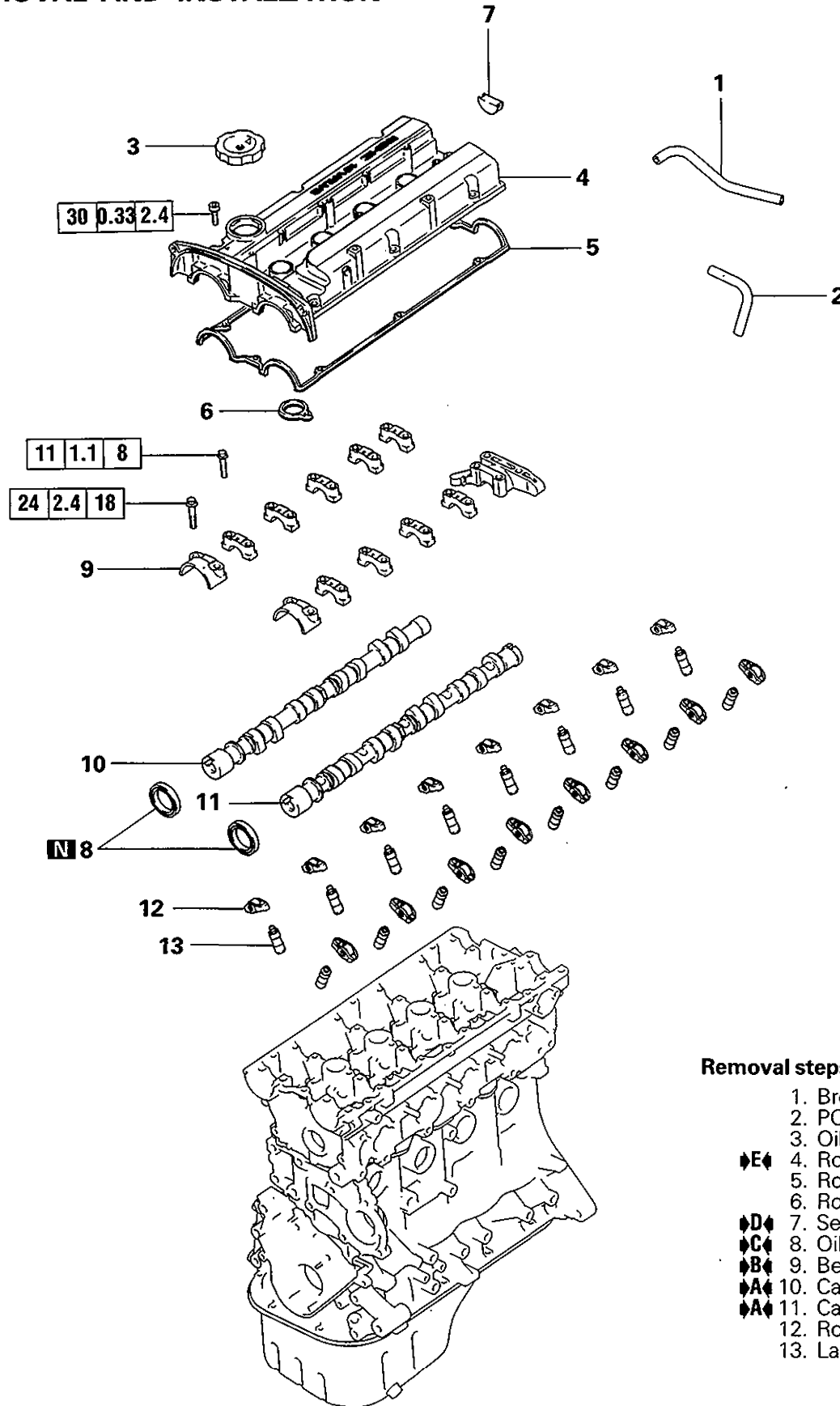

**Removal steps**

1. Breather hose
2. PCV hose
3. Oil filler cap
- ↔E↔ 4. Rocker cover
5. Rocker cover gasket A
6. Rocker cover gasket B
- ↔D↔  
↔C↔ 7. Semi-circular packing
- ↔B↔ 8. Oil seal
- ↔A↔ 9. Bearing cap
- ↔A↔ 10. Camshaft
11. Camshaft
12. Rocker arm
13. Lash adjuster

51

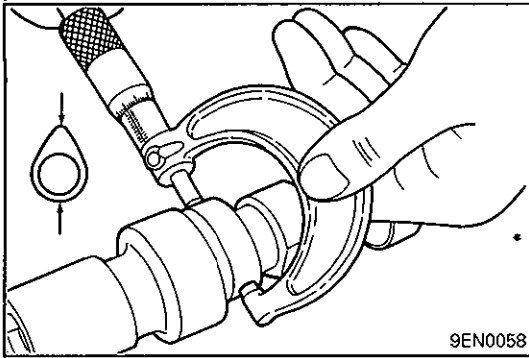

## INSPECTION

### CAMSHAFT

(1) Measure the cam height

#### Standard value:

##### Identification mark: B

Intake 35.31 mm (1.3902 in.)

Exhaust 35.20 mm (1.3858 in.)

##### Identification mark: D

Intake 35.31 mm (1.3902 in.)

Exhaust 35.32 mm (1.3905 in.)

##### Identification mark: E

Intake 35.60 mm (1.4016 in.)

Exhaust 35.49 mm (1.3972 in.)

#### Limit:

##### Identification mark: B

Intake 34.81 mm (1.3705 in.)

Exhaust 34.70 mm (1.3661 in.)

##### Identification mark: D

Intake 34.81 mm (1.3705 in.)

Exhaust 34.82 mm (1.3709 in.)

##### Identification mark: E

Intake 35.10 mm (1.3819 in.)

Exhaust 34.99 mm (1.3776 in.)

## LEAK DOWN TEST OF LASH ADJUSTER

### Caution

- The lash adjuster is a precision part. Keep it free from dust and other foreign matters.
- Do not disassemble lash adjuster.
- When cleaning lash adjuster, use clean diesel fuel only.

- (1) Immerse the lash adjuster in clean diesel fuel.
- (2) While lightly pushing down inner steel ball using the special tool (Air bleed wire MD998442), move the plunger up and down four or five times to bleed air. Use of the special tool (Retainer MD998441) helps facilitate the air bleeding of the rocker arm mounted type lash adjuster.
- (3) Remove the special tool (Air bleed wire MD998442) and press the plunger. If the plunger is hard to be pushed in, the lash adjuster is normal. If the plunger can be pushed in all the way readily, bleed the lash adjuster again and test again. If the plunger is still loose, replace the lash adjuster.

### Caution

- Upon completion of air bleeding, hold lash adjuster upright to prevent inside diesel fuel from spilling.
- (4) After air bleeding, set lash adjuster on the special tool (Leak down tester MD998440).
  - (5) After plunger has gone down 0.2 – 0.5 mm (0.008 – 0.020 in.), measure time taken for it to go down 1 mm (0.04 in.). Replace if measured time is out of specification.

**Standard value: 4 – 20 seconds/1 mm (0.04 in.)**  
**[Diesel fuel at 15 – 20°C (59 – 68°F)]**

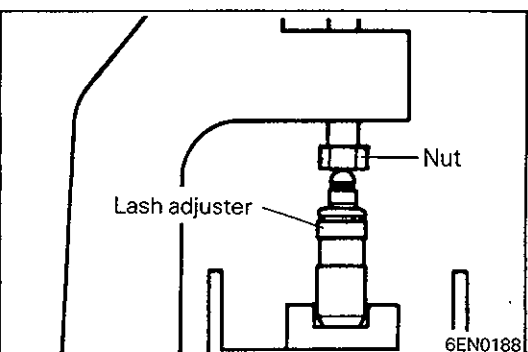
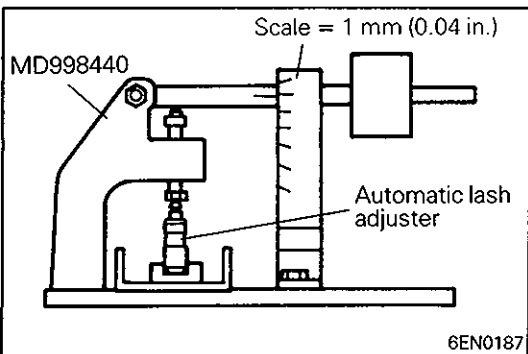
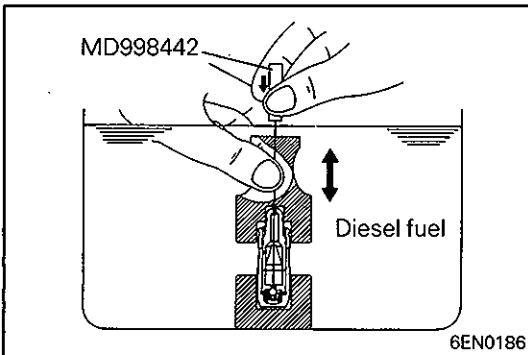

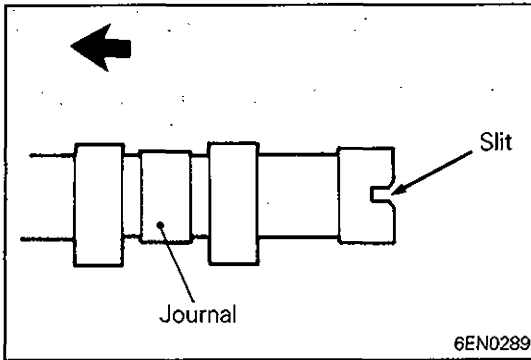

**SERVICE POINTS OF INSTALLATION**

**▶A▶ INSTALLATION OF CAMSHAFT**

- (1) Apply engine oil to the camshaft journals and cam before installing the camshaft. Use care not to confuse the intake camshaft with the exhaust camshaft.

**NOTE:**

The rear end of the intake camshaft is provided with a 4 mm-wide slit.

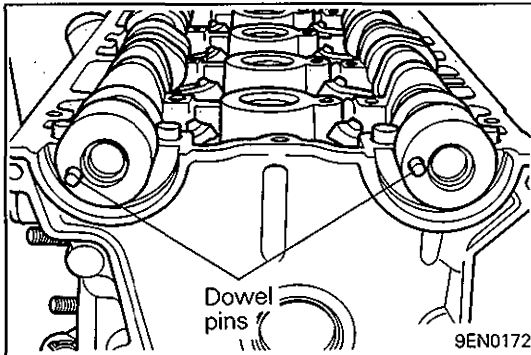

**▶B▶ INSTALLATION OF BEARING CAP**

- (1) Locate the camshaft dowel pins as illustrated.

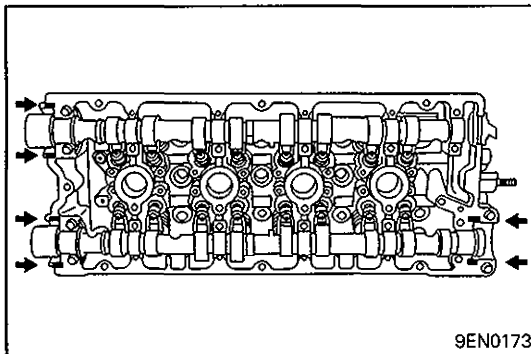

- (2) Apply sealant to the locations shown in the illustration.

**Specified sealant:**

**3M ATD Part No. 8660 or equivalent**

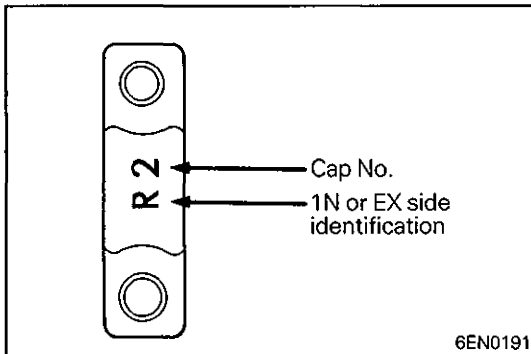

- (3) The bearing caps No. 2 through No. 5 are of the same shape. Before they are installed, check the cap number and the intake and exhaust identification marks.

**Identification mark** (stamped on front and No. 2 through No. 5 bearing caps)

**L** ..... Intake side  
**R** ..... Exhaust side

- (4) Make sure that the rocker arms are installed in the specified locations.

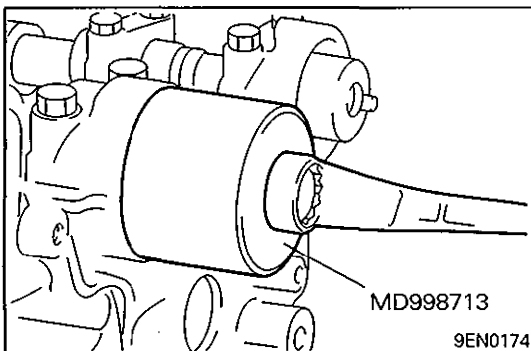

**▶C▶ INSTALLATION OF OIL SEAL**

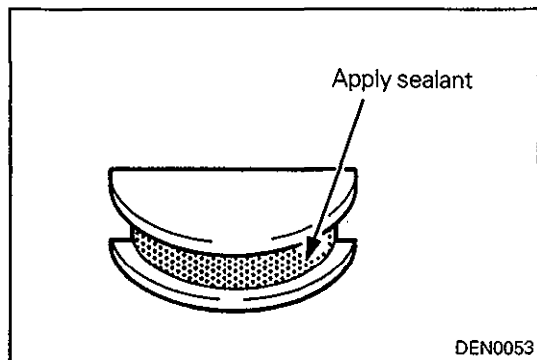
**◆D◆ APPLICATION OF SEALANT ON SEMI-CIRCULAR PACKING**

**Specified sealant: 3M ATD Part No. 8660 or equivalent**

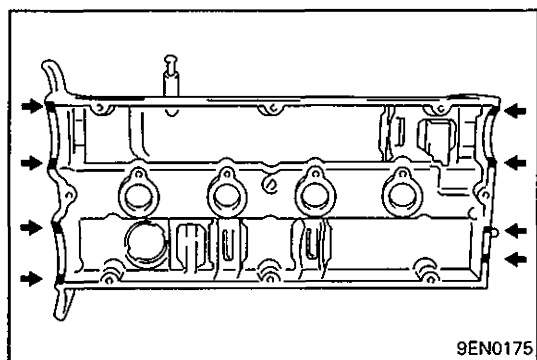
**◆E◆ APPLICATION OF SEALANT ON ROCKER COVER**

(1) Apply sealant to the areas indicated in the illustration.

**Specified sealant: 3M ATD Part No. 8660 or equivalent**

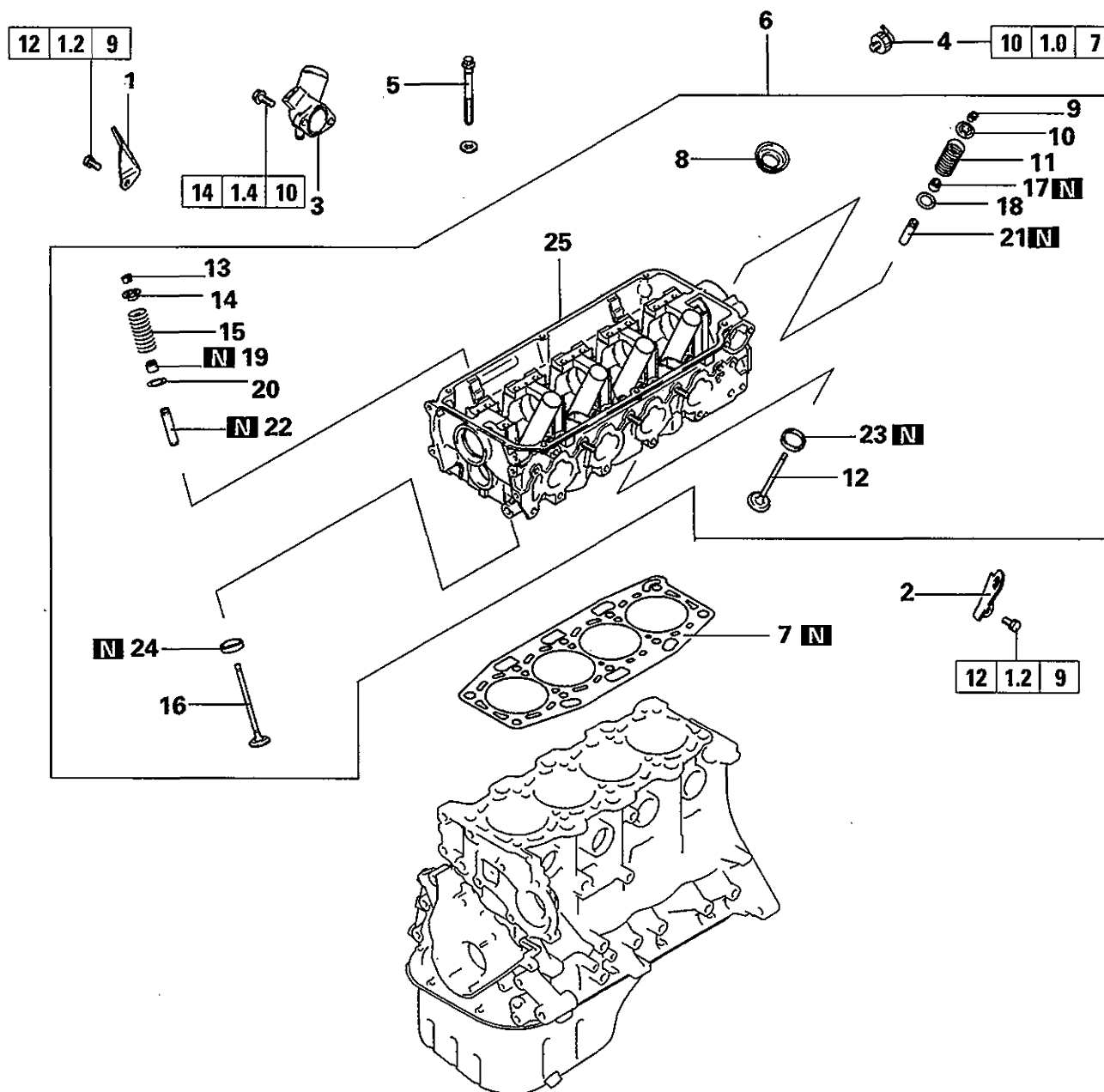
**15. CYLINDER HEAD AND VALVES (SINGLE CAMSHAFT ENGINE)****REMOVAL AND INSTALLATION (FRONT WHEEL DRIVE VEHICLE)****Removal steps**

- |         |                           |         |                           |
|---------|---------------------------|---------|---------------------------|
|         | 1. Engine hanger          |         | 14. Valve spring retainer |
|         | 2. Engine hanger          | ↗B↖     | 15. Valve spring          |
| ↗F↖     | 3. Water outlet fitting   | ↗E↖     | 16. Exhaust valve         |
| ↗D↖     | 4. Oil pressure switch    | ↗C↖ ↗A↖ | 17. Valve stem seal       |
| ↗A↖ ↗D↖ | 5. Cylinder head bolt     | ↗C↖ ↗A↖ | 18. Valve spring seat     |
|         | 6. Cylinder head assembly | ↗C↖ ↗A↖ | 19. Valve stem seal       |
|         | 7. Cylinder head gasket   |         | 20. Valve spring seat     |
|         | 8. Oil seal               |         | 21. Intake valve guide    |
| ↗B↖ ↗C↖ | 9. Retainer lock          |         | 22. Exhaust valve guide   |
|         | 10. Valve spring retainer |         | 23. Intake valve seat     |
| ↗B↖     | 11. Valve spring          |         | 24. Exhaust valve seat    |
|         | 12. Intake valve          |         | 25. Cylinder head         |
| ↗B↖ ↗C↖ | 13. Retainer lock         |         |                           |

REMOVAL AND INSTALLATION (REAR WHEEL DRIVE VEHICLE)

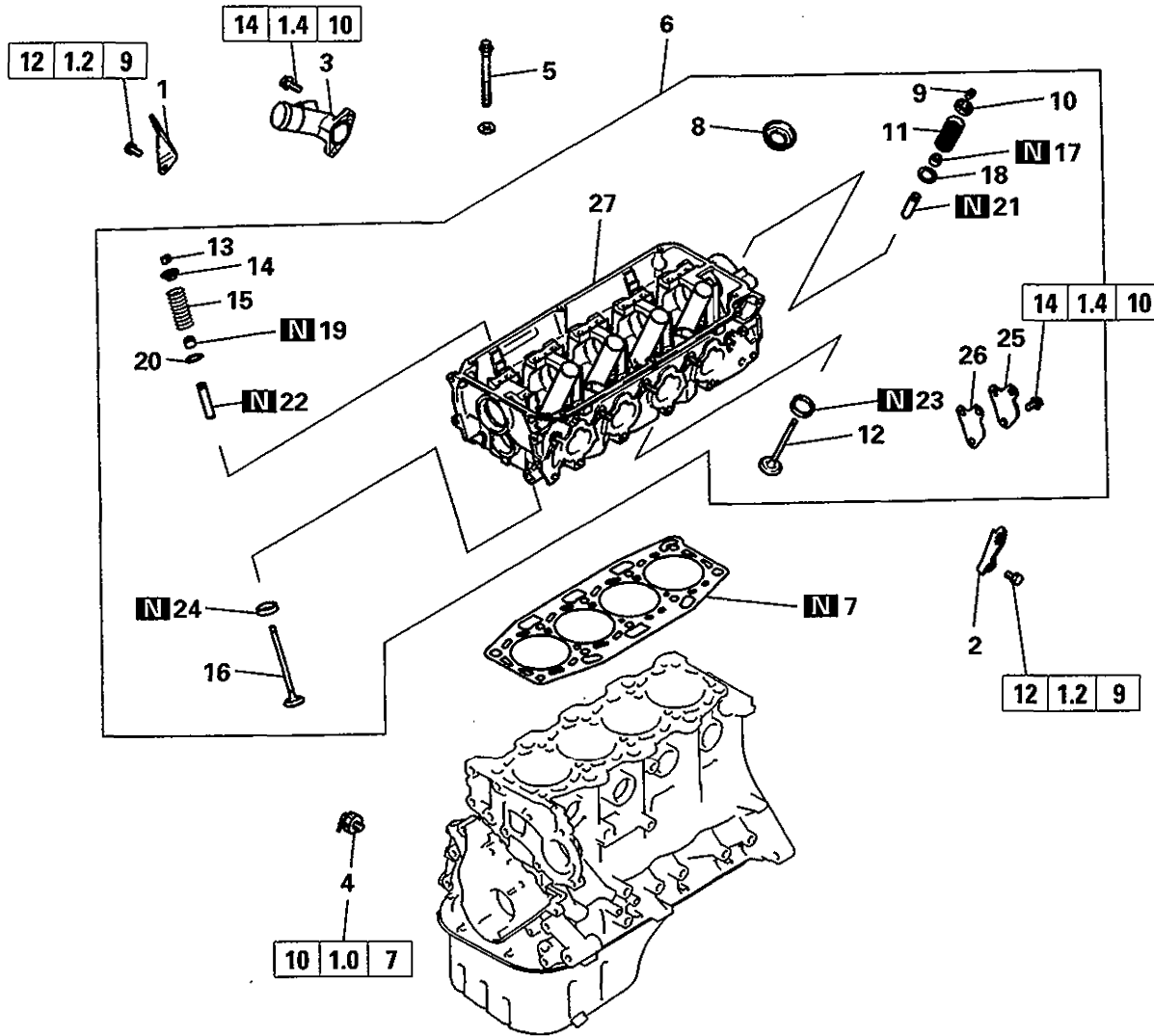

Removal steps

- |   |   |
|---|---|
| 1. Engine hanger  | $\blacktriangleleft\blacktriangleright$ 15. Valve spring      |
| $\blacktriangleleft\blacktriangleright$ 2. Engine hanger          | 16. Exhaust valve   |
| $\blacktriangleleft\blacktriangleright$ 3. Water outlet fitting   | $\blacktriangleleft\blacktriangleright$ 17. Valve stem seal   |
| $\blacktriangleleft\blacktriangleright$ 4. Oil pressure switch    | $\blacktriangleleft\blacktriangleright$ 18. Valve spring seat |
| $\blacktriangleleft\blacktriangleright$ 5. Cylinder head bolt     | $\blacktriangleleft\blacktriangleright$ 19. Valve stem seal   |
| 6. Cylinder head assembly   | $\blacktriangleleft\blacktriangleright$ 20. Valve spring seat |
| 7. Cylinder head gasket   | 21. Intake valve guide  |
| 8. Oil seal   | 22. Exhaust valve guide                                       |
| $\blacktriangleleft\blacktriangleright$ 9. Retainer lock          | 23. Intake valve seat   |
| 10. Valve spring retainer   | 24. Exhaust valve seat  |
| $\blacktriangleleft\blacktriangleright$ 11. Valve spring          | 25. Water outlet hole cover                                   |
| 12. Intake valve  | 26. Gasket  |
| $\blacktriangleleft\blacktriangleright$ 13. Retainer lock         | 27. Cylinder head   |
| $\blacktriangleleft\blacktriangleright$ 14. Valve spring retainer |   |

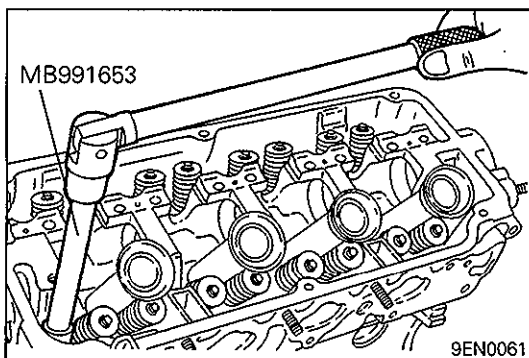
**SERVICE POINTS OF REMOVAL****◁A▷ REMOVAL OF CYLINDER HEAD BOLT**

- (1) Using the special tool, loosen the cylinder head bolts.

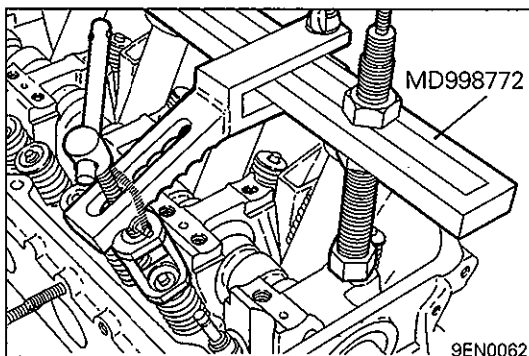
**◁B▷ REMOVAL OF RETAINER LOCK**

- (1) Store removed valves, springs and other parts, tagged to indicate their cylinder No. and location for reassembly.

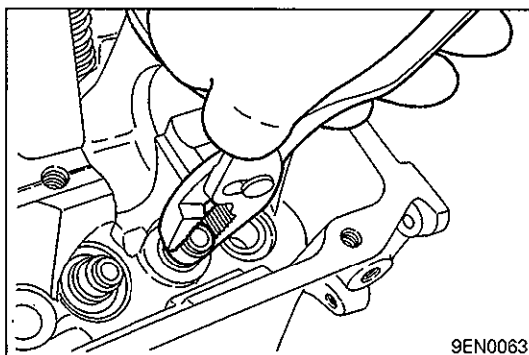
**◁C▷ REMOVAL OF VALVE STEM SEAL**

- (1) Do not reuse valve stem seal.

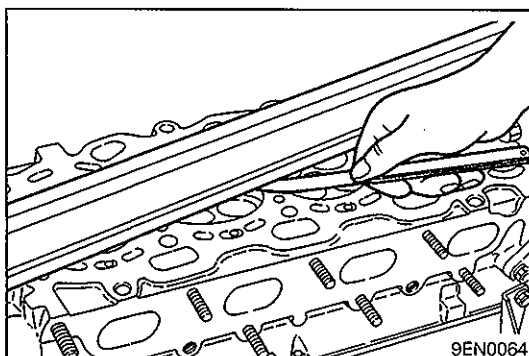
**INSPECTION****CYLINDER HEAD**

- (1) Check the cylinder head gasket surface for flatness by using a straightedge and thickness gauge.

**Standard value: 0.03 mm (0.0012 in.)**

**Limit: 0.2 mm (0.008 in.)**

- (2) If the service limit is exceeded, correct to meet specification.

**Grinding limit: \*0.2 mm (0.008 in.)**

\* Includes grinding of with cylinder block.

**Cylinder head height (Specification when new):**  
**119.9 – 120.1 mm (4.720 – 4.728 in.)**

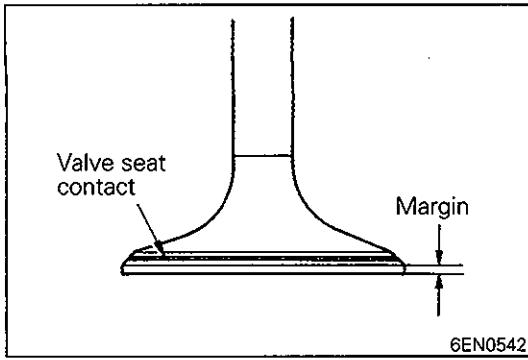

**VALVE**

- (1) Check the valve face for correct contact. If incorrect, reface using valve refacer. Valve seat contact should be maintained uniform at the center of valve face.
- (2) If the margin is smaller than the service limit, replace the valve.

**Standard value:**

<b>Intake</b>	<b>1.0 mm (0.039 in.)</b>
<b>Exhaust</b>	<b>1.3 mm (0.051 in.)</b>

**Limit:**

<b>Intake</b>	<b>0.5 mm (0.020 in.)</b>
<b>Exhaust</b>	<b>0.8 mm (0.031 in.)</b>

- (3) Measure the overall height of the valve. If the measurement exceeds the specified limit, replace the valve.

**Standard value:**

<b>Intake</b>	<b>110.15 mm (4.3366 in.)</b>
<b>Exhaust</b>	<b>113.70 mm (4.4764 in.)</b>

**Limit:**

<b>Intake</b>	<b>109.65 mm (4.3169 in.)</b>
<b>Exhaust</b>	<b>113.20 mm (4.4567 in.)</b>

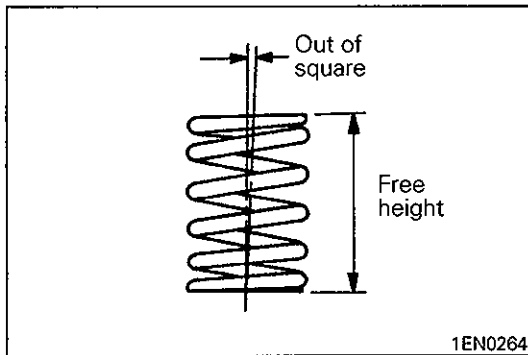
**VALVE SPRING**

- (1) Measure the free height of the spring and, if it is smaller than the limit, replace.

**Standard value: 50.9 mm (2.004 in.)****Limit: 49.9 mm (1.965 in.)**

- (2) Measure the squareness of the spring and, if the limit is exceeded, replace.

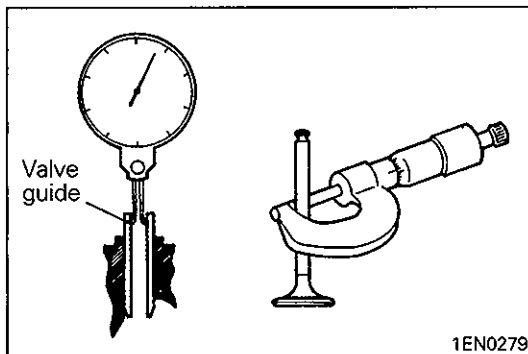
**Standard value: 2° or less****Limit: 4°****VALVE GUIDE**

- (1) Measure the clearance between the valve guide and valve stem. If the limit is exceeded, replace the valve guide or valve, or both.

**Standard value:**

<b>Intake</b>	<b>0.02 – 0.04 mm (0.0008 – 0.0016 in.)</b>
<b>Exhaust</b>	<b>0.03 – 0.06 mm (0.0012 – 0.0024 in.)</b>

**Limit:**

<b>Intake</b>	<b>0.10 mm (0.0039 in.)</b>
<b>Exhaust</b>	<b>0.15 mm (0.0059 in.)</b>

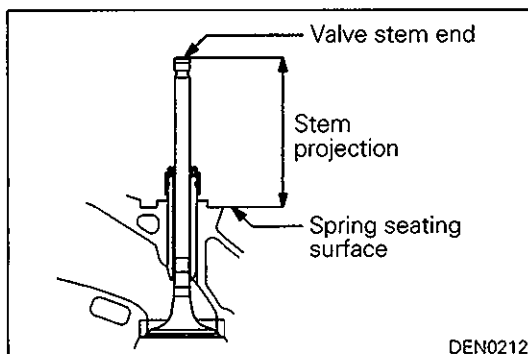
**VALVE SEAT**

- (1) Assemble the valve, then measure the valve stem projection between the end of the valve stem and the spring seating surface. If the measurement exceeds the specified limit, replace the valve seat.

**Standard value:**

<b>Intake</b>	<b>49.30 mm (1.9409 in.)</b>
<b>Exhaust</b>	<b>49.35 mm (1.9429 in.)</b>

**Limit:**

<b>Intake</b>	<b>49.80 mm (1.9606 in.)</b>
<b>Exhaust</b>	<b>49.85 mm (1.9626 in.)</b>

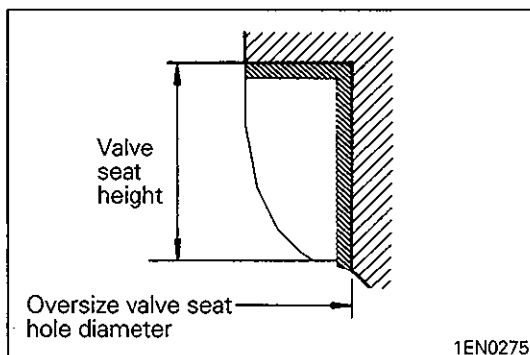
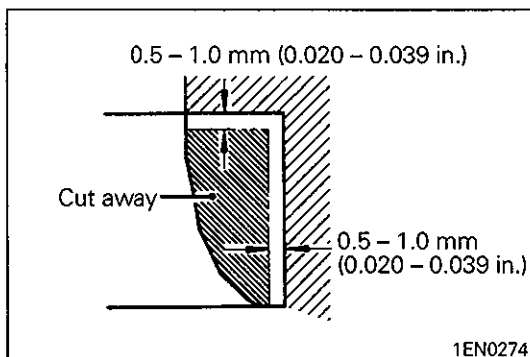
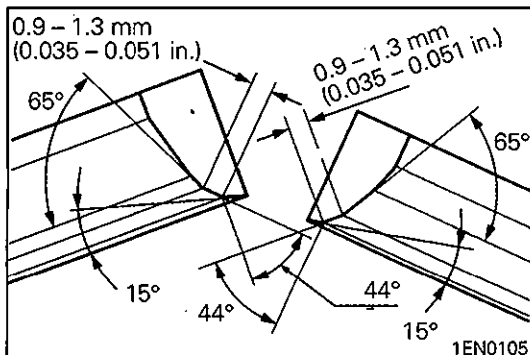
**VALVE SEAT RECONDITIONING PROCEDURE**

- (1) Before correcting the valve seat, check the clearance between the valve guide and valve. If necessary, replace the valve and/or valve guide.
- (2) Using the appropriate special tool or seat grinder, correct the valve seat to achieve the specified seat width and angle.
- (3) After correcting the valve seat, lap the valve and valve seat using lapping compound. Then, check the valve stem projection (refer to VALVE SEAT in INSPECTION).

**VALVE SEAT REPLACEMENT PROCEDURE**

- (1) Cut the valve seat to be replaced from the inside to thin the wall thickness. Then, remove the valve seat.
- (2) Rebore the valve seat hole in the cylinder head to a selected oversize valve seat diameter.

**Intake valve seat hole diameter**

<b>0.3 O.S.:</b>	<b>31.80 – 31.83 mm (1.2520 – 1.2531 in.)</b>
<b>0.6 O.S.:</b>	<b>32.10 – 32.13 mm (1.2638 – 1.2650 in.)</b>

**Exhaust valve seat hole diameter**

<b>0.3 O.S.:</b>	<b>29.30 – 29.32 mm (1.1534 – 1.1543 in.)</b>
<b>0.6 O.S.:</b>	<b>29.60 – 29.62 mm (1.1653 – 1.1661 in.)</b>

- (3) Before fitting the valve seat, either heat the cylinder head up to approximately 250°C or cool the valve seat in liquid nitrogen, to prevent the cylinder head bore from galling.
- (4) Correct the valve seat to the specified width and angle.

**VALVE GUIDE REPLACEMENT**

- (1) Force the valve guide out toward the cylinder block using a press.
- (2) Machine the valve guide hole in the cylinder head to the size of the oversize valve guide to be installed.

**Caution**

- Do not use the valve guide of the same size as the removed one.

**Valve guide hole diameters in cylinder head**

0.05 O.S.:	11.05 – 11.07 mm (0.4350 – 0.4358 in.)
0.25 O.S.:	11.25 – 11.27 mm (0.4429 – 0.4437 in.)
0.50 O.S.:	11.50 – 11.52 mm (0.4528 – 0.4535 in.)

- (3) Press-fit the valve guide until it protrude specified value (14 mm) as shown in the illustration.

**Caution**

- Press the valve guide from the cylinder head top surface.
- Valve guide for intake valve and that for exhaust valve are different in length. (45.5 mm for intake valve; 50.5 mm for exhaust valve)

- (4) After the valve guide has been installed, insert a new valve to check for smooth sliding motion.

**SERVICE POINTS OF REASSEMBLY****▶A◀ INSTALLATION OF VALVE STEM SEAL**

- (1) Install the valve spring seat.
- (2) The special tool must be used to install the valve stem seal. Improper installation could result in oil leaking past the valve guide.

**Caution**

- Do not reuse valve stem seal.

**▶B◀ INSTALLATION OF VALVE SPRING**

- (1) Install the valve spring with the painted end on the rocker arm side.

**▶C◀ INSTALLATION OF RETAINER LOCK**

- (1) The valve spring, if excessively compressed, causes the bottom end of retainer to be in contact with, and damage, the stem seal.

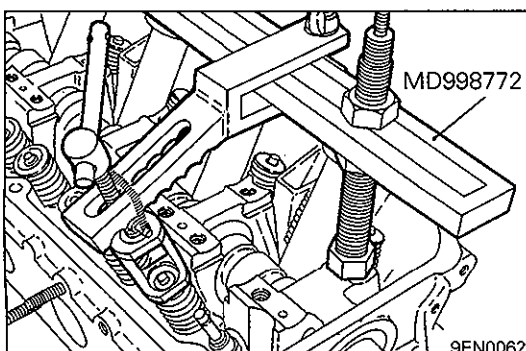
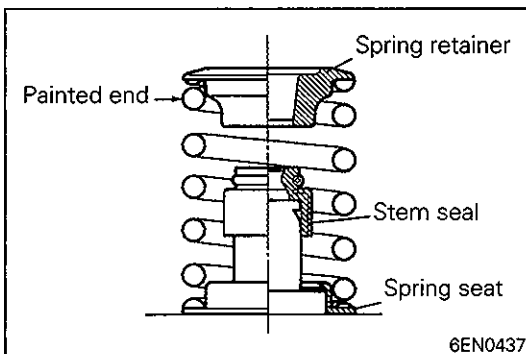
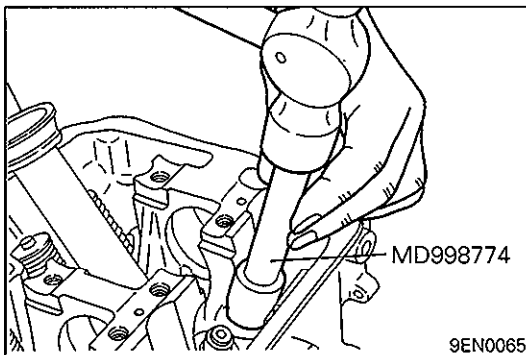
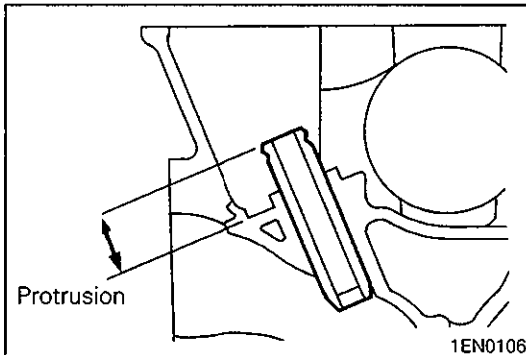

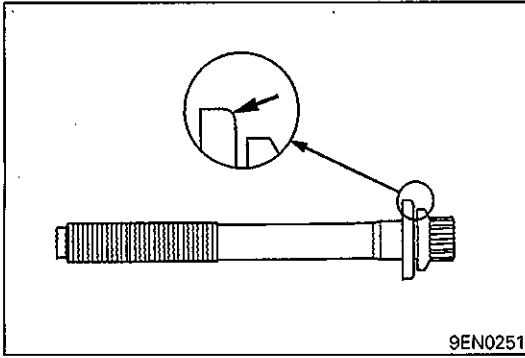

### ◆◆ INSTALLATION OF CYLINDER HEAD BOLT

- (1) When installing the cylinder head bolts, check that the shank length of each bolt meets the limit. If the limit is exceeded, replace the bolt.

**Limit: Max. 96.4 mm (3.79 in.)**

- (2) Install the washers as illustrated.
- (3) Apply engine oil to the bolt threads and washers.

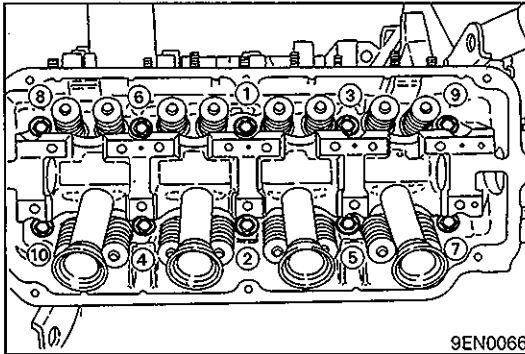

- (4) According to the tightening sequence, tighten the bolts to the specified torque 75 Nm (7.5 kgm, 54 ft.lbs.) using the special fool (MB991653).

- (5) Loosen all bolts fully.

- (6) Retighten the loosened bolts to a torque of 20 Nm (2.0 kgm, 14.5 ft.lbs.) in the specified tightening sequence.

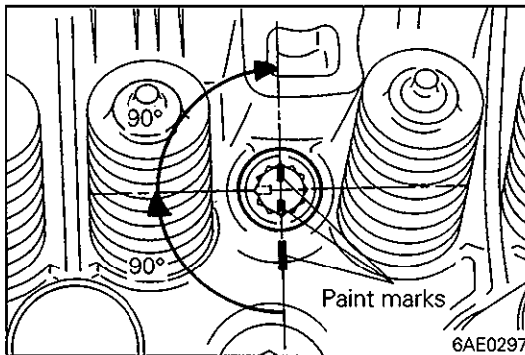

- (7) Make paint marks on the cylinder head bolt heads and cylinder head.

- (8) Give a 90° turn to the cylinder head bolts in the specified tightening sequence.

- (9) Give another 90° turn to the cylinder head bolts and make sure that the paint mark on the head of each cylinder head bolt and that on the cylinder head are on the same straight line.

### Caution

- If the bolt is turned less than 90°, proper fastening performance may not be expected. When tightening the bolt, therefore, be careful to give a sufficient turn to it.
- If the bolt is overtightened, loosen the bolt completely and then retighten it by repeating the tightening procedure from step (1).

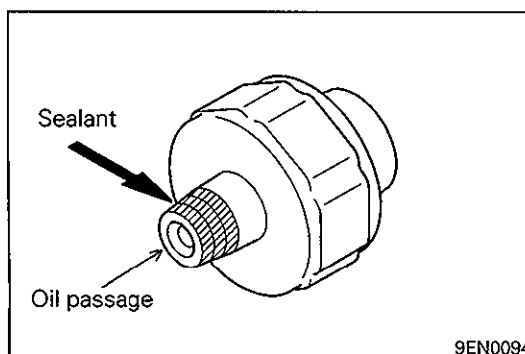

### ◆◆ APPLICATION OF SEALANT TO OIL PRESSURE SWITCH

- (1) Apply sealant to the threads of the switch.

### Specified sealant:

**3M ATD Part No. 8660 or equivalent**

### Caution

- Use care not to allow the sealant to plug the oil passage.

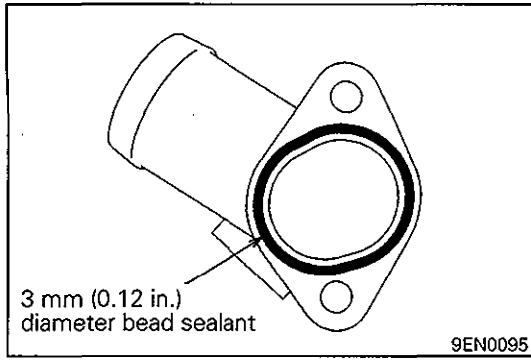

**⇄ F ⇄ APPLICATION OF SEALANT TO WATER OUTLET FITTING**

**Specified sealant:**  
**Mitsubishi Genuine Part No. MD970389 or equivalent**

4/12

## 16. CYLINDER HEAD AND VALVES (DOUBLE CAMSHAFT ENGINE)

## REMOVAL AND INSTALLATION

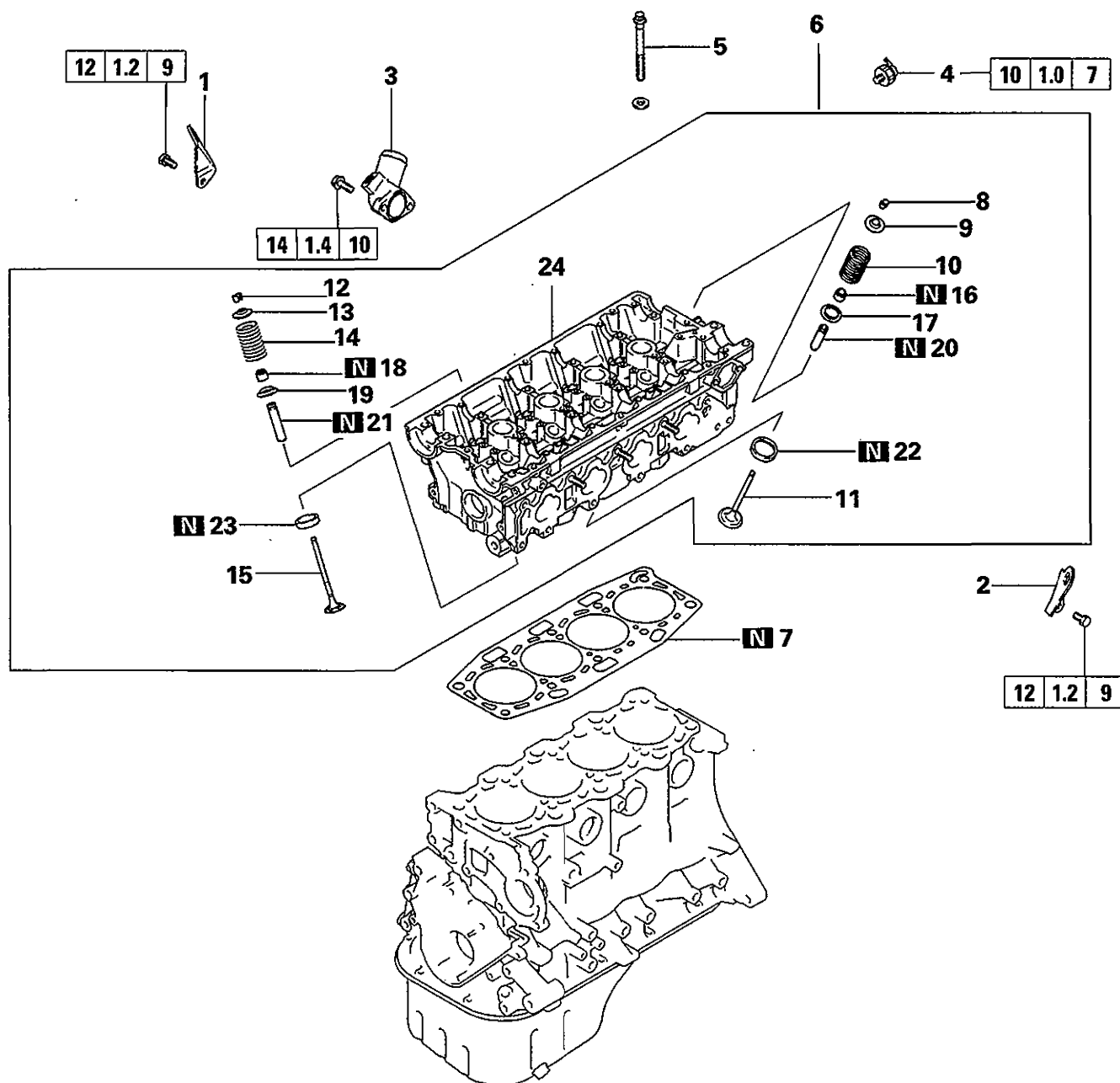

## Removal steps

- |         |                           |         |                           |                     |
|---------|---------------------------|---------|---------------------------|---------------------|
|         | 1. Engine hanger          |         | 13. Valve spring retainer |                     |
|         | 2. Engine hanger          | ▶B◀     | 14. Valve spring          |                     |
|         | 3. Water outlet fitting   | ▶F◀     | 15. Exhaust valve         |                     |
|         | 4. Oil pressure switch    | ▶E◀     | ▶C◀ ▶A◀                   | 16. Valve stem seal |
| ◀A◀ ▶D◀ | 5. Cylinder head bolt     | ▶C◀ ▶A◀ | 17. Valve spring seat     |                     |
|         | 6. Cylinder head assembly | ▶C◀ ▶A◀ | 18. Valve stem seal       |                     |
| ◀B◀ ▶C◀ | 7. Cylinder head gasket   |         | 19. Valve spring seat     |                     |
|         | 8. Retainer lock          |         | 20. Intake valve guide    |                     |
|         | 9. Valve spring retainer  |         | 21. Exhaust valve guide   |                     |
| ▶B◀     | 10. Valve spring          |         | 22. Intake valve seat     |                     |
|         | 11. Intake valve          |         | 23. Exhaust valve seat    |                     |
| ◀B◀ ▶C◀ | 12. Retainer lock         |         | 24. Cylinder head         |                     |

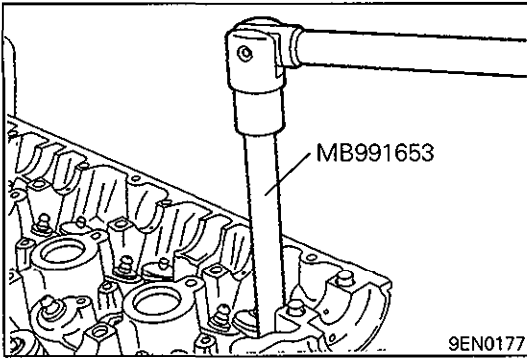
**SERVICE POINTS OF REMOVAL****◁A▷ REMOVAL OF CYLINDER HEAD BOLT**

- (1) Using the special tool, loosen the cylinder head bolts.

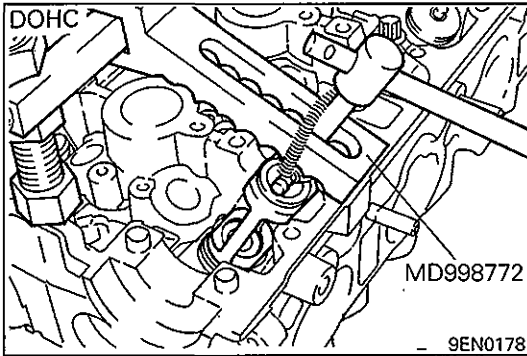
**◁B▷ REMOVAL OF RETAINER LOCK**

- (1) Store removed valves, springs and other parts, tagged to indicate their cylinder No. and location for reassembly.

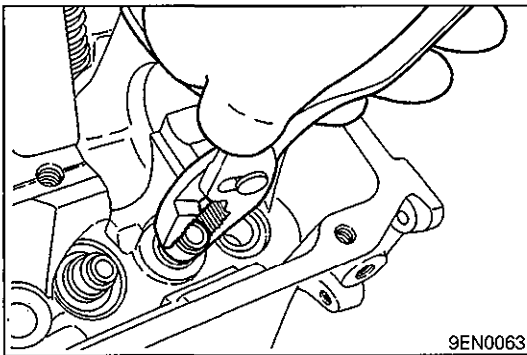
**◁C▷ REMOVAL OF VALVE STEM SEAL**

- (1) Do not reuse valve stem seal.

**INSPECTION**

- (1) Only features differing from the single camshaft engine are described in the following. (Refer to Pages 11A-15-3 and 5.)

**CYLINDER HEAD**

**Cylinder head height (when new):**

**131.9 – 132.1 mm (5.193 – 5.201 in.)**

**VALVE****Margin:**

Intake 1.0 mm (0.039 in.)

Exhaust 1.2 mm (0.047 in.)

**Limit:**

Intake 0.5 mm (0.020 in.)

Exhaust 0.7 mm (0.023 in.)

**Overall length:**

Intake 104.19 mm (4.1020 in.)

Exhaust 103.87 mm (4.0894 in.)

**Limit:**

Intake 103.69 mm (4.0823 in.)

Exhaust 103.37 mm (4.0697 in.)

**VALVE SPRING****4G91**

Free height: 44.4 mm (1.748 in.)

Limit: 43.4 mm (1.709 in.)

Squareness: 2° or less

Limit: Max. 4°

**4G93**

Free height: 45.0 mm (1.772 in.)

Limit: 44.0 mm (1.732 in.)

Squareness: 2° or less

Limit: Max. 4°

**VALVE GUIDE****Valve guide to valve stem clearance:**

Intake 0.02 – 0.05 mm (0.0008 – 0.0020 in.)

Exhaust 0.05 – 0.09 mm (0.0020 – 0.0035 in.)

**Limit:**

Intake 0.10 mm (0.004 in.)

Exhaust 0.15 mm (0.006 in.)

**VALVE SEAT****Valve stem projection**

Intake 46.70 mm (1.8386 in.)

Exhaust 46.65 mm (1.8366 in.)

**Limit:**

Intake 47.20 mm (1.8583 in.)

Exhaust 47.15 mm (1.8563 in.)

**VALVE SEAT RECONDITIONING PROCEDURE**

Refer to Page 11A-15-6.

**VALVE SEAT REPLACEMENT PROCEDURE**

Refer to Pages 11A-15-6 and 11A-15-7.

**Intake valve seat hole diameter**

0.3 O.S.: 34.30 – 34.33 mm (1.3504 – 1.3518 in.)

0.6 O.S.: 34.60 – 34.63 mm (1.3622 – 1.3634 in.)

**Exhaust valve seat hole diameter**

0.3 O.S.: 30.80 – 30.83 mm (1.2125 – 1.2138 in.)

0.6 O.S.: 31.10 – 31.13 mm (1.2244 – 1.2256 in.)



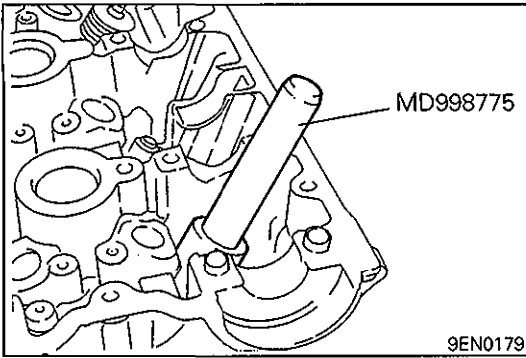

## SERVICE POINTS OF REASSEMBLY

### ▶A▶ INSTALLATION OF VALVE STEM SEAL

- (1) Install the valve spring seat.
- (2) The special tool must be used to install the valve stem seal. Improper installation could result in oil leaking past the valve guide.

#### Caution

- Do not reuse valve stem seal.

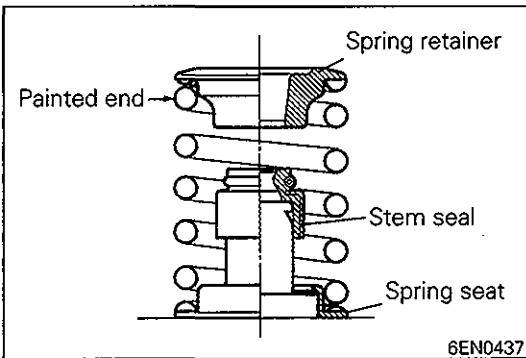

### ▶B▶ INSTALLATION OF VALVE SPRING

- (1) Install the valve spring with the painted end on the rocker arm side.

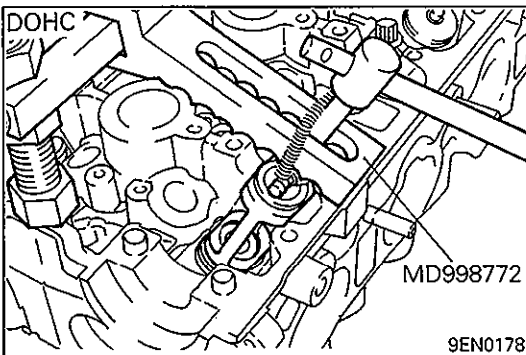

### ▶C▶ INSTALLATION OF RETAINER LOCK

- (1) The valve spring, if excessively compressed, causes the bottom end of retainer to be in contact with, and damage, the stem seal.

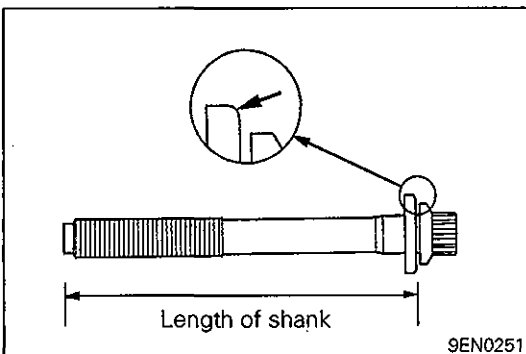

### ▶D▶ INSTALLATION OF CYLINDER HEAD BOLT

- (1) When installing the cylinder head bolts, check that the shank length of each bolt meets the limit. If the limit is exceeded, replace the bolt.

**Limit: max. 96.4 mm (3.79 in.)**

- (2) Install the washers as illustrated.
- (3) Apply engine oil to the bolt threads and washers.

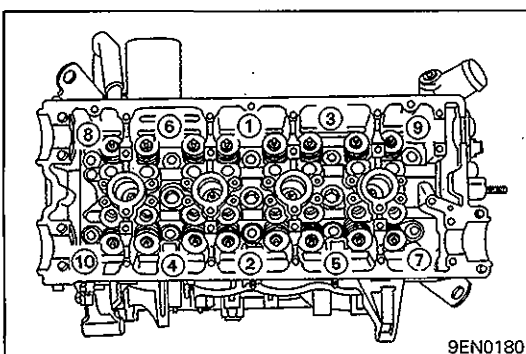

- (4) According to the tightening sequence, tighten the bolts to the specified torque 75 Nm (7.5 kgm, 54 ft.lbs.) using the special tool (MB991653).
- (5) Loosen all bolts fully.
- (6) Retighten the loosened bolts to a torque of 20 Nm (2.0 kgm, 14.5 ft.lbs.) in the specified tightening sequence.

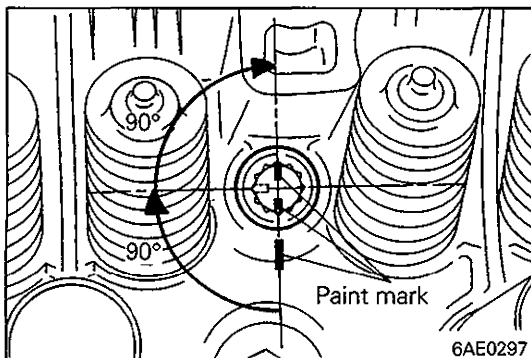

- (7) Make paint marks on the cylinder head bolt heads and cylinder head.
- (8) Give a 90° turn to the cylinder head bolts in the specified tightening sequence.
- (9) Give another 90° turn to the cylinder head bolts and make sure that the paint mark on the head of each cylinder head bolt and that on the cylinder head are on the same straight line.

**Caution**

- If the bolt is turned less than 90°, proper fastening performance may not be expected. When tightening the bolt, therefore, be careful to give a sufficient turn to it.
- If the bolt is overtightened, loosen the bolt completely and then retighten it by repeating the tightening procedure from step (1).

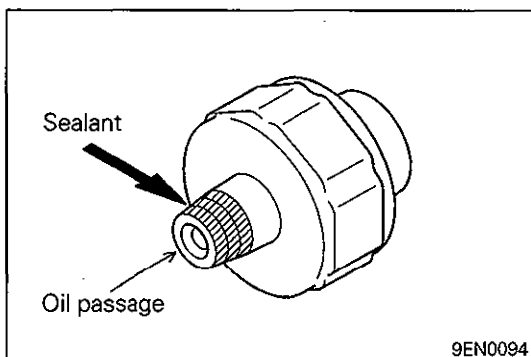
**▶E◀ APPLICATION OF SEALANT TO OIL PRESSURE SWITCH**

- (1) Apply sealant to the threads of the switch.

**Specified sealant:**

**3M ATD Part No. 8660 or equivalent**

**Caution**

- Use care not to allow the sealant to plug the oil passage.

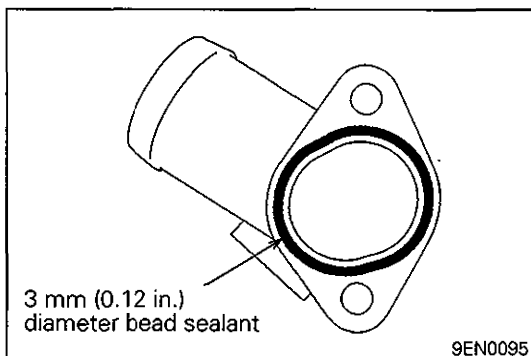
**▶F◀ APPLICATION OF SEALANT TO WATER OUTLET FITTING****Specified sealant:**

**Mitsubishi Genuine Part No. MD970389 or equivalent**

---

NOTES

# 17. FRONT CASE AND OIL PUMP

## REMOVAL AND INSTALLATION

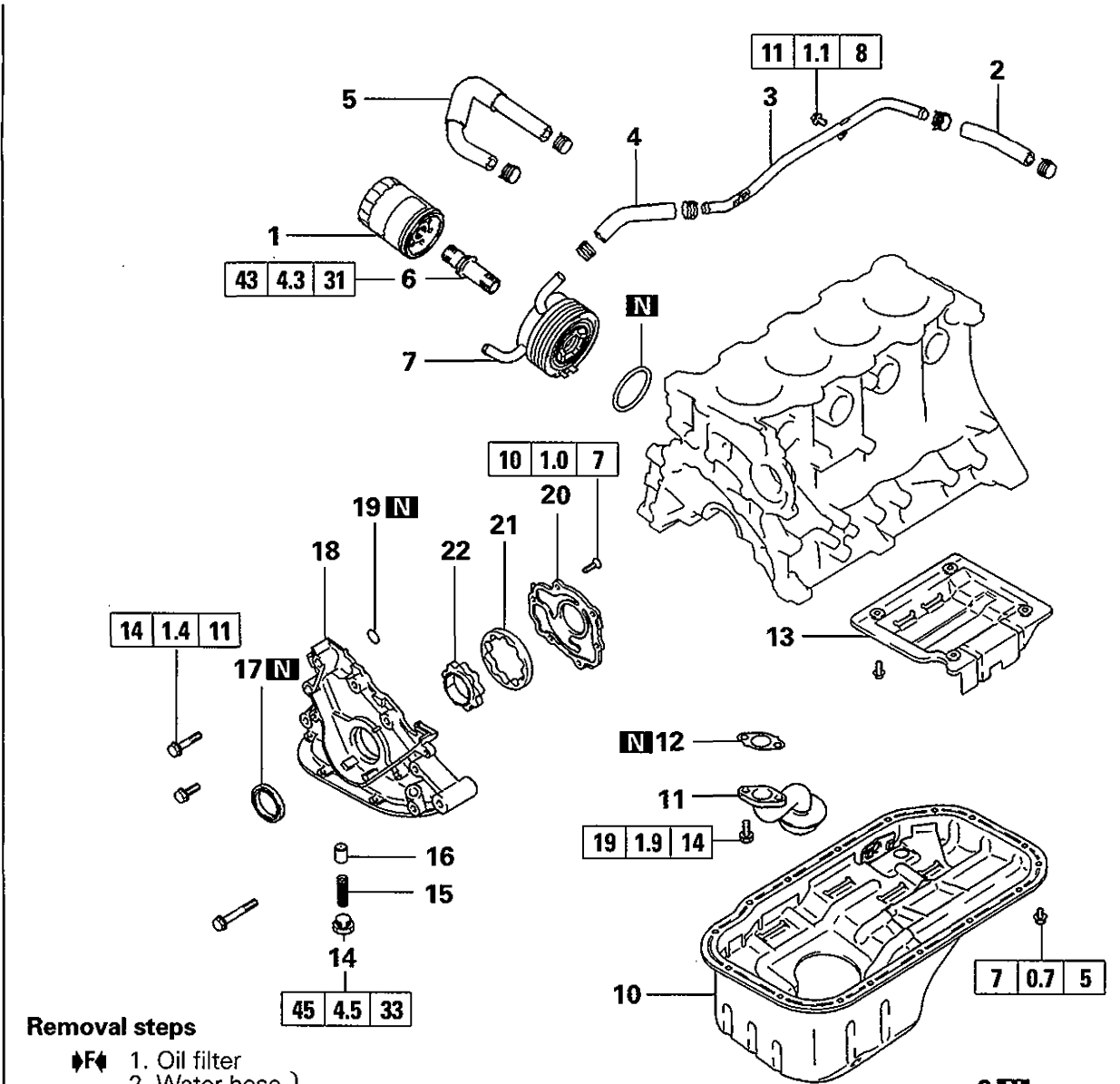

### Removal steps

- ◆F◆ 1. Oil filter
- 2. Water hose
- 3. Water pipe
- 4. Water hose
- 5. Water hose } Engine with turbocharger
- 6. Bolt
- ◆E◆ 7. Oil cooler
- 8. Drain plug
- 9. Drain plug gasket
- ◀A▶ ◆D▶ 10. Oil pan
- 11. Oil screen
- 12. Oil screen gasket
- 13. Baffle plate (Engine with turbocharger)
- 14. Relief plug
- 15. Relief spring
- 16. Relief plunger
- ◆C◆ 17. Oil seal
- ◆B◆ 18. Oil pump case
- 19. O-ring
- 20. Oil pump case cover
- ◀B▶ ◆A▶ 21. Outer rotor
- ◀B▶ ◆A▶ 22. Inner rotor

5/6

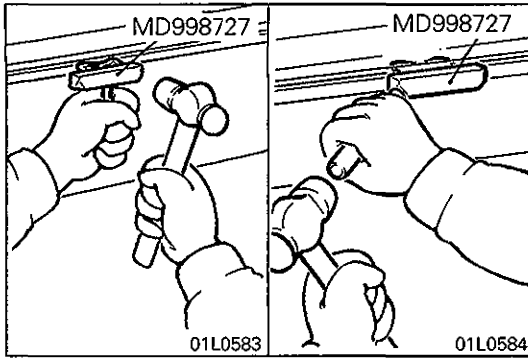
**SERVICE POINTS OF REMOVAL****◀A▶ REMOVAL OF OIL PAN**

- (1) Knock in the special tool deeply between the oil pan and the cylinder block.
- (2) Hitting the side of the special tool, slide the special tool along the oil pan to remove the oil pan.

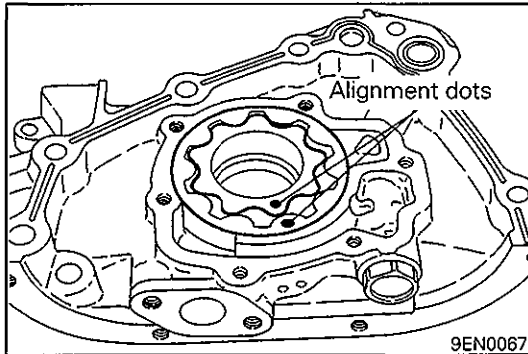
**◀B▶ REMOVAL OF OUTER ROTOR / INNER ROTOR**

- (1) Make alignment dots on the outer and inner rotors for reassembly.

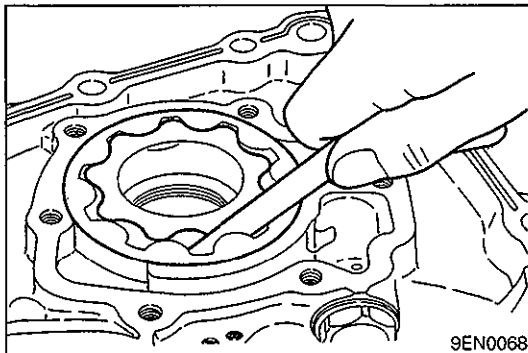
**INSPECTION****OIL PUMP**

- (1) Check the tip clearance.

**Standard value: 0.06 – 0.18 mm (0.0024 – 0.0071 in.)**

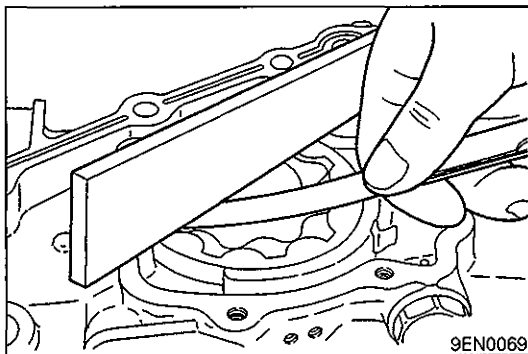

- (2) Check the side clearance.

**Standard value: 0.04 – 0.10 mm (0.0016 – 0.0039 in.)**

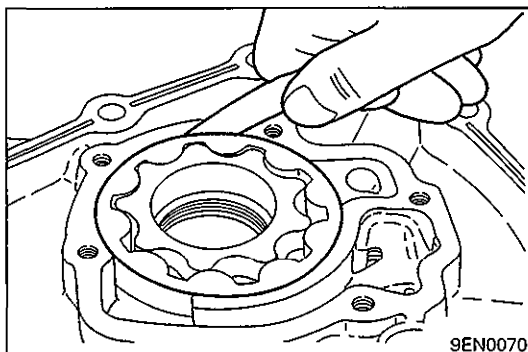

- (3) Check the body clearance.

**Standard value: 0.10 – 0.18 mm (0.0039 – 0.0071 in.)**

**Limit: 0.35 (0.0138 in.)**

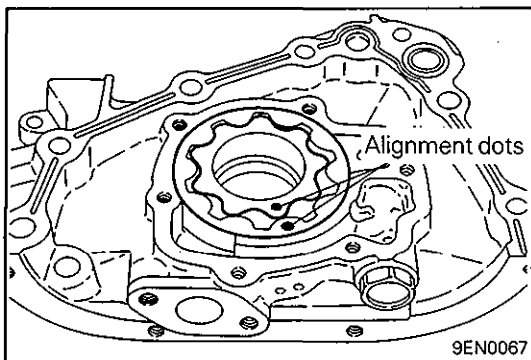
**SERVICE POINTS OF INSTALLATION****◆A◆ INSTALLATION OF INNER ROTOR / OUTER ROTOR**

- (1) Apply engine oil to the rotors. Then, install the rotors ensuring that the alignment dots made at disassembly are properly aligned.

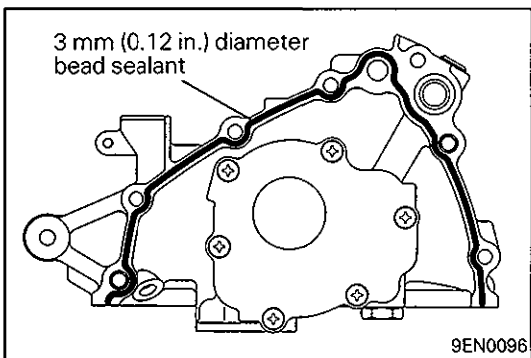
**◆B◆ APPLICATION OF SEALANT TO OIL PUMP CASE****Specified sealant:**

**Mitsubishi Genuine Part No. MD970389 or equivalent**

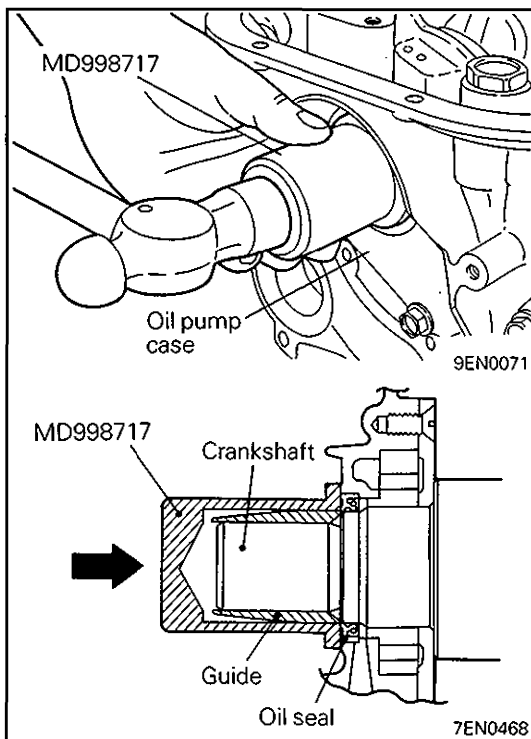
**◆C◆ INSTALLATION OF CRANKSHAFT FRONT OIL SEAL**

Using the special tool, knock the oil seal into the oil pump case.

**⇨⇩ INSTALLATION OF OIL PAN**

- (1) Remove all the remaining gasket from the mating surfaces using a scraper or a wire brush.
- (2) Apply a 4 mm (0.16 in.) diameter bead of sealant to the oil pan flange.  
See "Form In-Place Gasket" in introduction.

**Specified sealant:**

**Mitsubishi Genuine Part No. MD970389 or equivalent**

- (3) The oil pan should be installed within 15 minutes after the application of sealant.

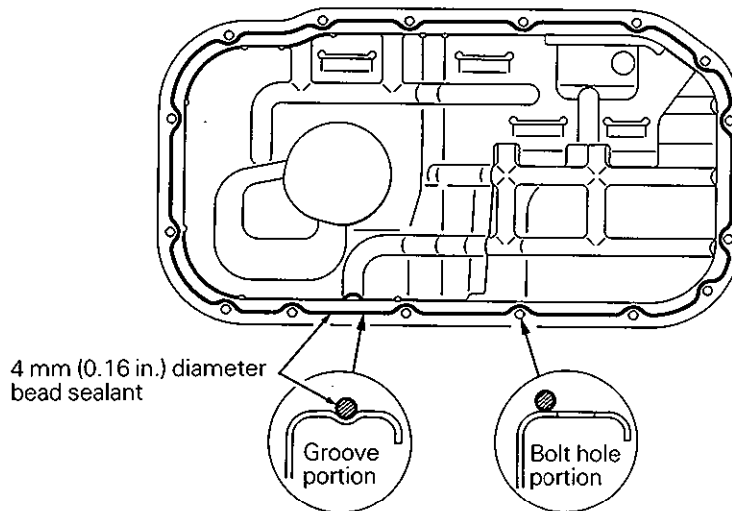

9EN0097

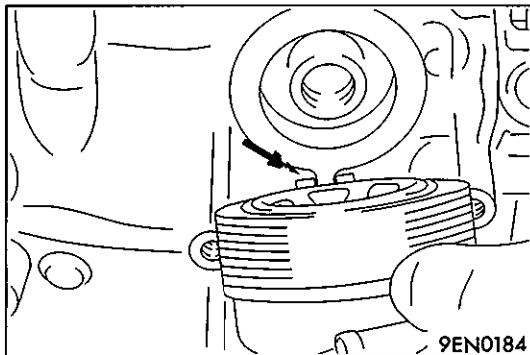
**⇨⇩ INSTALLATION OF OIL COOLER**

- (1) Install the oil cooler with its locating projections properly positioned in relation to the rib on the cylinder block side.

**⇨⇩ INSTALLATION OF OIL FILTER**

- (1) Clean the installation surface of cylinder block side.
- (2) Apply engine oil to the O-ring of the oil filter.
- (3) Screw in the oil filter until its O-ring contacts to the base.  
Then tighten one more turn.

# 18. PISTON AND CONNECTING ROD

## REMOVAL AND INSTALLATION

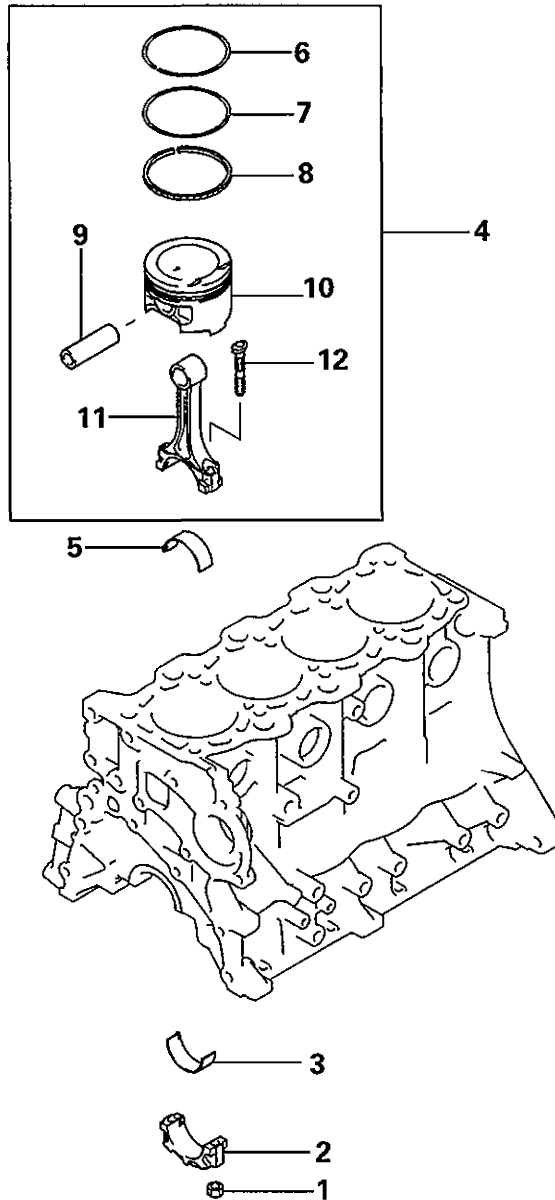

### Removal steps

- ↔G↔ 1. Nut
- ↔A↔ ↔F↔ 2. Connecting rod cap
- ↔E↔ 3. Connecting rod bearing
- ↔D↔ 4. Piston and connecting rod
- ↔E↔ 5. Connecting rod bearing
- ↔C↔ 6. Piston ring No. 1
- ↔C↔ 7. Piston ring No. 2
- ↔B↔ 8. Oil ring
- ↔B↔ ↔A↔ 9. Piston pin
- 10. Piston
- 11. Connecting rod
- 12. Bolt

5/13



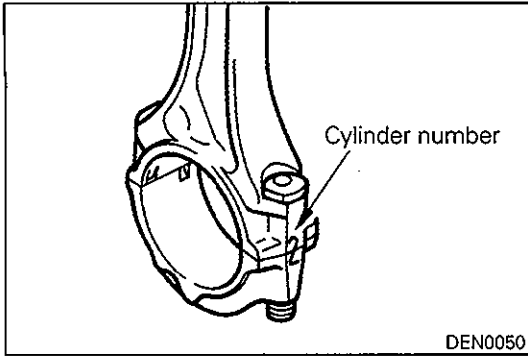

**SERVICE POINTS OF DISASSEMBLY**

**◁A▷ REMOVAL OF CONNECTING ROD CAP**

- (1) Mark the large end of the connecting rod with the cylinder number for use during reassembly.

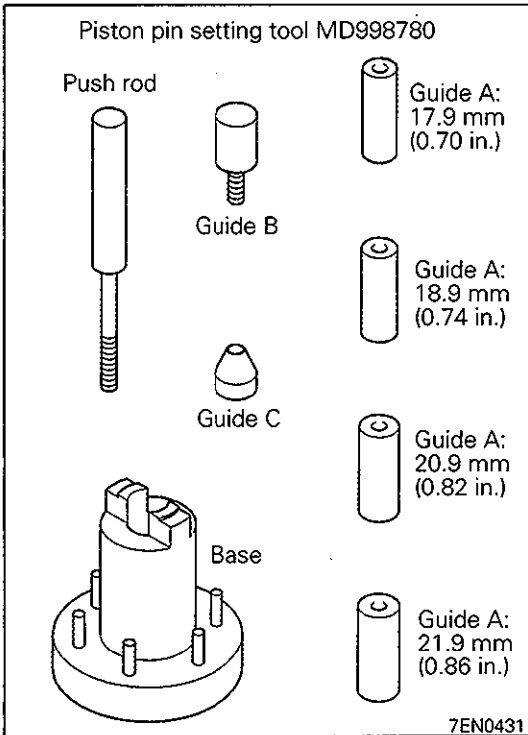

**◁B▷ REMOVAL OF PISTON PIN**

- (1) Piston pin setting tool (MD998780) consists of the parts shown in the illustration at left. To remove the piston pin, Guide D (MD991659) should be used in combination with this special tool.

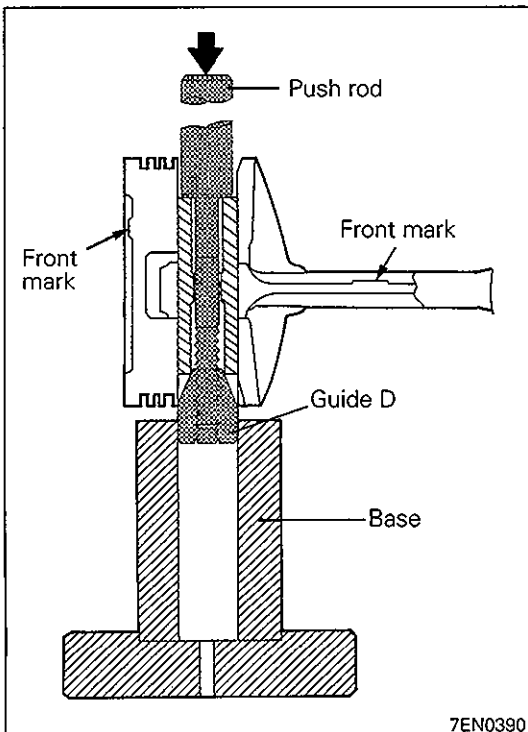

- (1) Insert the Push Rod (special tool) into the piston from the side on which the front mark is stamped in the piston head, and attach the guide D to the push rod end.
- (2) Place the piston and connecting rod assembly on the Piston Pin Setting Base (special tool) with the front mark facing upward.
- (3) Using a press, remove the piston pin.

**NOTE**

Keep the disassembled pistons, piston pins and connecting rods in order according to the cylinder number.

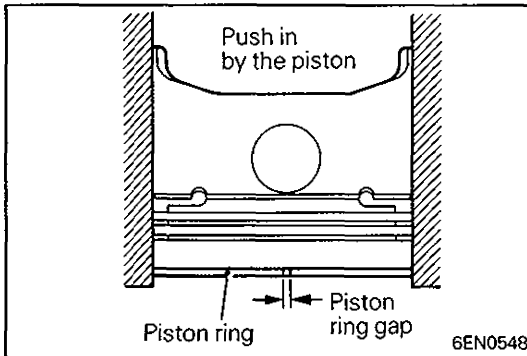
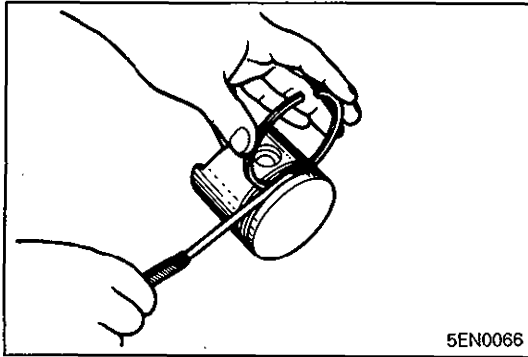
**INSPECTION****PISTON RING**

- (1) Check the side clearance between the piston ring and ring groove. If the limit is exceeded, replace the ring or piston, or both.

**Standard value:**

No. 1	0.03 – 0.07 mm (0.0012 – 0.0028 in.)
No. 2	0.02 – 0.06 mm (0.0008 – 0.0024 in.)

**Limit:**

No. 1	0.1 mm (0.004 in.)
No. 2	0.1 mm (0.004 in.)

Install the piston ring into the cylinder bore. Force it down with a piston, its crown being in contact with the ring, to correctly position it at right angles to the cylinder wall. Then, measure the end gap with a feeler gauge. If the ring gap is excessive, replace piston ring.

**Standard value:**

No. 1	0.25 – 0.40 mm (0.0098 – 0.0157 in.)
No. 2	0.40 – 0.55 mm (0.0157 – 0.0217 in.)

**Oil**

**4G91, 4G92 and 4G93 – Single Camshaft Engine**  
0.20 – 0.60 mm (0.0079 – 0.0236 in.)

**4G93 – Double Camshaft Engine**  
0.10 – 0.35 mm (0.0039 – 0.0138 in.)

**Limit:**

No. 1, No. 2	0.8 mm (0.031 in.)
Oil	1.0 mm (0.039 in.)

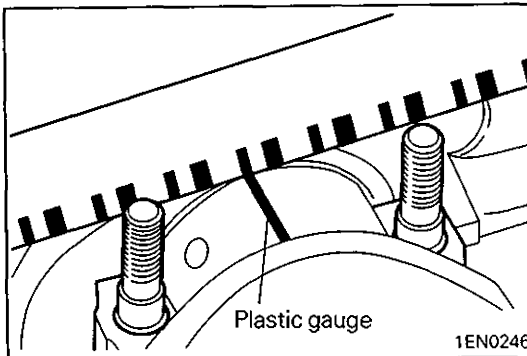
**CRANKSHAFT PIN OIL CLEARANCE (PLASTIC GAUGE METHOD)**

- (1) Remove oil from crankshaft pin and connecting rod bearing.
- (2) Cut the plastic gauge to the same length as the width of bearing and place it on crankshaft pin in parallel with its axis.
- (3) Install the connecting rod cap carefully and tighten the bolts to specified torque.
- (4) Carefully remove the connecting rod cap.
- (5) Measure the width of the plastic gauge at its widest part by using a scale printed on the plastic gauge package.

**Standard value: 0.02 – 0.05 mm (0.0008 – 0.0020 in.)**

**Limit: 0.1 mm (0.004 in.)**

**SERVICE POINTS OF INSTALLATION**

**◆◆ INSTALLATION OF PISTON PIN**

- (1) Measure the following dimensions of the piston, piston pin and connecting rod.  
 A: Piston pin insertion hole length  
 B: Distance between piston bosses  
 C: Piston pin length  
 D: Connecting rod small end width
- (2) Calculate the following formula by substituting the measured values.

$$L = \frac{(A - C) - (B - D)}{2}$$

- (3) Insert the Push Rod (special tool) into the piston pin and attach the guide A to the push rod end.
- (4) Assemble the connecting rod in the piston with their front marks facing the same direction.
- (5) Apply engine oil to the entire periphery of the piston pin.
- (6) Insert the piston pin, push rod and guide A assembly having assembled in step (3) from the guide A side into the piston pin hole on the front marked side.

- (7) Screw the guide B into the guide A until the gap between both guides amounts to the value L obtained in step (2) plus 3 mm (0.12 in.).

- (8) Place the piston and connecting rod assembly onto the piston setting base with the front marks directed upward.
- (9) Press-fit the piston pin using a press.  
 If the press-fitting force required is less than the standard value, replace the piston and piston pin set or/and the connecting rod.

**Standard value: 5,000 – 15,000N (500 – 1,500 kg, 1,102 – 3,307 lbs.)**

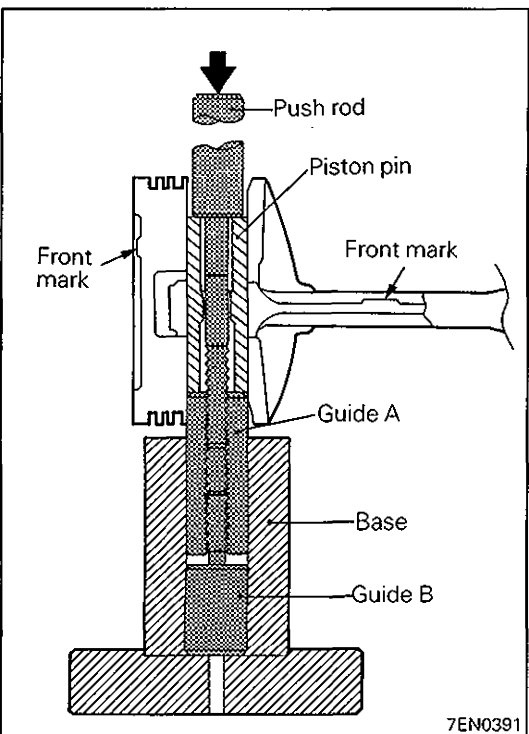
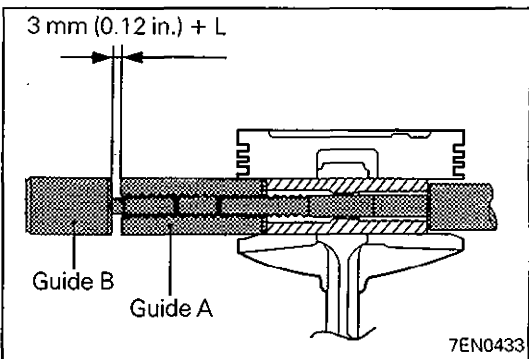
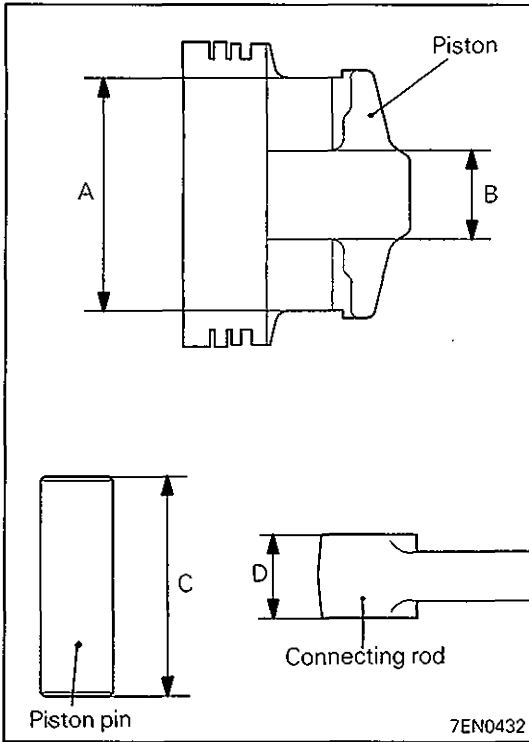

500

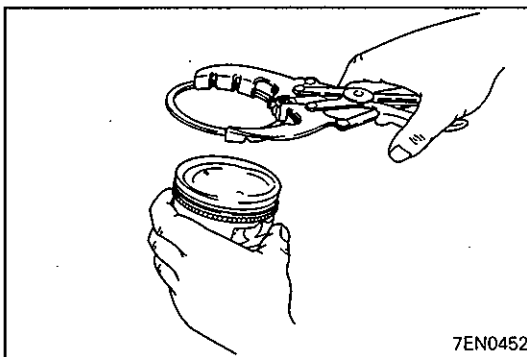
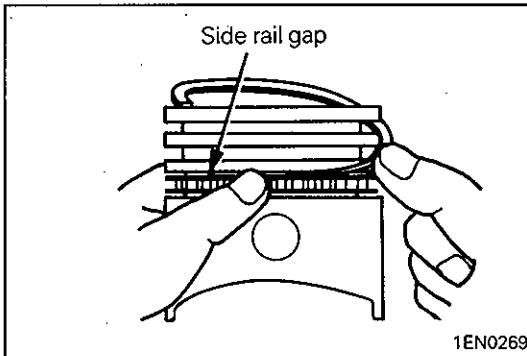
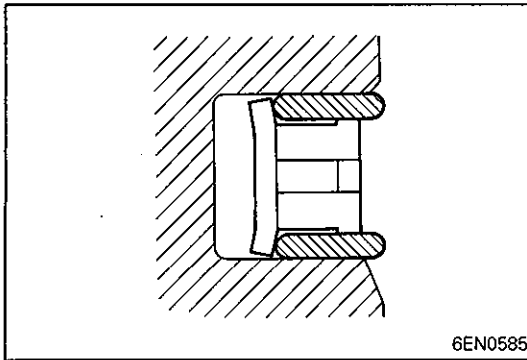

#### ◆B◆ INSTALLATION OF OIL RING

- (1) Fit the oil ring spacer into the piston ring groove.

##### NOTE

The side rails and spacer may be installed in either direction.

- (2) Install the upper side rail.  
To install the side rail, first fit one end of the rail into the piston groove, then press the remaining portion into position by finger. See illustration.

##### NOTE

Do not use piston ring expander when installing side rail. Use of ring expander to expand the side rail end gap can break the side rail, unlike other piston rings.

- (3) Install the lower side rail in the same procedure as described in step (2).
- (4) Make sure that the side rails move smoothly in either direction.

#### ◆C◆ INSTALLATION OF PISTON RING No. 2 / PISTON RING NO. 1

- (1) Using piston ring expander, fit No. 2 and then No. 1 piston ring into position.

##### NOTE

- (1) Identification marks are stamped at the ring ends.

Identification mark:

No. 1 ring T  
No. 2 ring T2

- (2) Install piston rings No. 1 and No. 2 with their side having marks facing up (on the piston crown side).

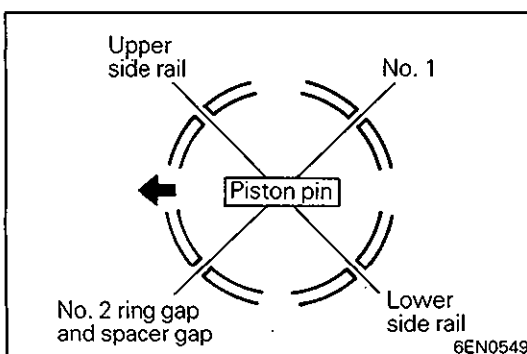

#### ◆D◆ INSTALLATION OF PISTON AND CONNECTING ROD

- (1) Liberally coat engine oil on the circumference of the piston, piston ring, and oil ring.
- (2) Arrange the piston ring and oil ring gaps (side rail and spacer) as shown in the figure.
- (3) Rotate crankshaft so that the crank pin is on center of the cylinder bore.

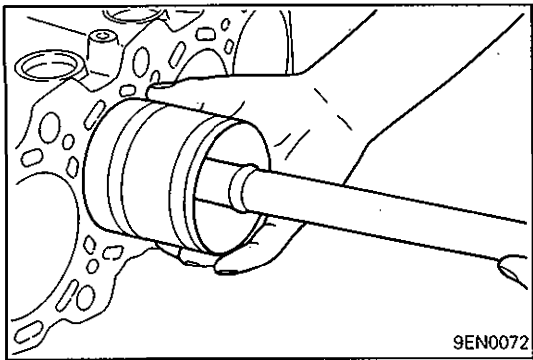

- (4) Use suitable thread protectors on connecting rod bolts before inserting piston and connecting rod assembly into cylinder block. Care must be taken not to nick crank pin.
- (5) Using a suitable piston ring compressor tool, install piston and connecting rod assembly into the cylinder block.

**Caution**

- **Insert the front mark (arrow) on the top of the piston so it faces the engine front (timing belt side).**

**▶◀ INSTALLATION OF CONNECTING ROD BEARINGS**

- (1) When the bearings are to be replaced, select correct ones and install them in the correct positions according to the identification marks stamped on the crankshaft.

Crankshaft		Connecting rod bearing		
Pin O.D. Identification mark	Pin O.D. mm (in.)	Identification mark (Service parts)	Identification color (Line production part)	Thickness mm (in.)
1	44.995 – 45.000 (1.7715 – 1.7717)	S1	Brown	1.487 – 1.491 (0.0585 – 0.0587)
2	44.985 – 44.995 (1.7711 – 1.7715)	S2	Black	1.491 – 1.495 (0.0587 – 0.0589)
3	44.980 – 44.985 (1.7709 – 1.7711)	S3	Green	1.495 – 1.499 (0.0589 – 0.0590)

Connecting rod I.D.: 48.000 – 48.015 mm (1.8898 – 1.8904 in.)

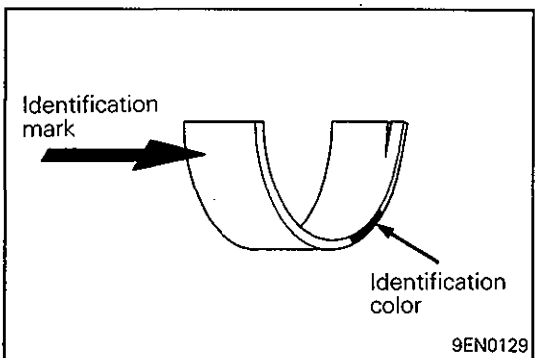
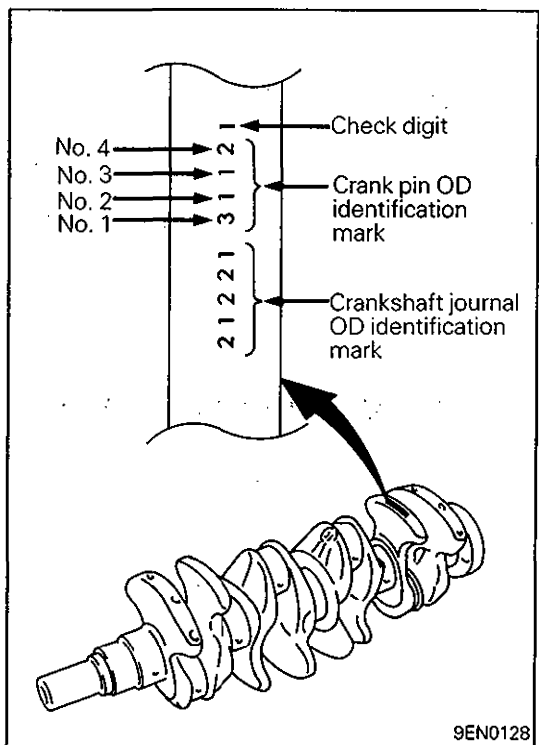

**▶◀ INSTALLATION OF CONNECTING ROD CAP**

- (1) Mate the correct bearing cap with the correct connecting rod by checking with the alignment marks marked during disassembly. If a new connecting rod is used which has no alignment mark, position the notches for locking the bearing on the same side.

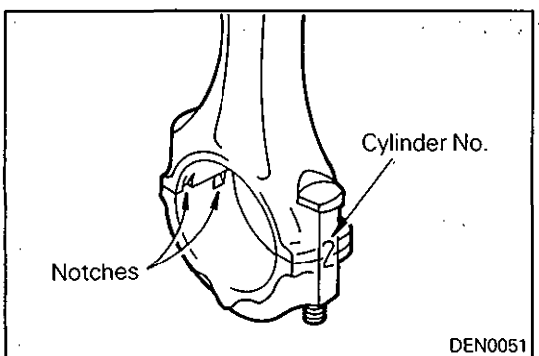

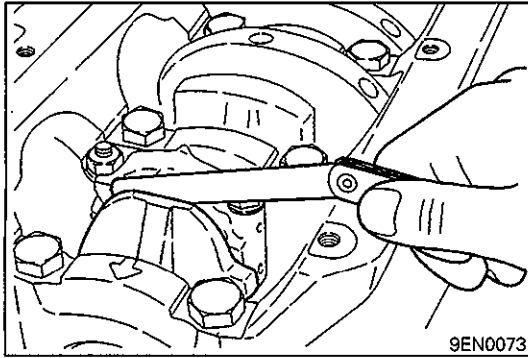

- (2) Check if the thrust clearance of the connecting rod big end is correct.

**Standard value: 0.10 – 0.25 mm (0.0039 – 0.0098 in.)**

**Limit: 0.4 mm (0.016 in.)**

### ◆G◆ CONNECTING ROD CAP NUT INSTALLATION

- (1) Since the connecting rod bolts and nuts are torqued using a new procedure they should be examined BEFORE reuse. If the bolt threads are "necked down" the bolts should be replaced.  
Necking can be checked by running a nut with fingers to the full length of the bolt's thread. If the nut does not run down smoothly, the bolt should be replaced.
- (2) Before installation of each nut, apply engine oil to the threaded portion and bearing surface of the nut.
- (3) Loosely tighten each nut to the bolt.  
Then tighten the nuts alternately to a torque of 20 Nm (2.0 kgm, 14.5 ft.lbs.) to install the cap properly.

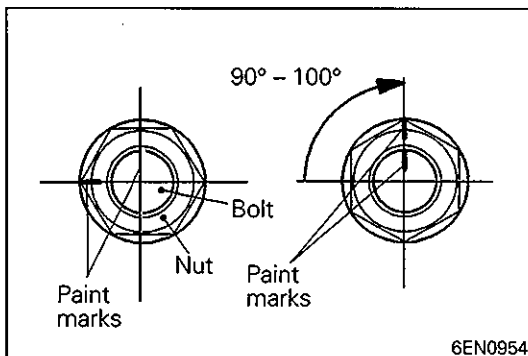

- (4) Make a paint mark on the head of each nut.
- (5) Make a paint mark on the bolt at the position 90° to 100° from the paint mark made on the nut in the direction of tightening the nut.
- (6) Give a 90° to 100° turn to the nut and make sure that the paint mark on the nut and that on the bolt are in alignment.

#### Caution

- If the nut is turned less than 90°, proper fastening performance may not be expected. When tightening the nut, therefore, be careful to give a sufficient turn to it.
- If the nut is overtightened (exceeding 100°), loosen the nut completely and retighten it by repeating the tightening procedure from step (1).

---

NOTES

# 19. CRANKSHAFT, CYLINDER BLOCK, FLYWHEEL AND DRIVE PLATE

## REMOVAL AND INSTALLATION

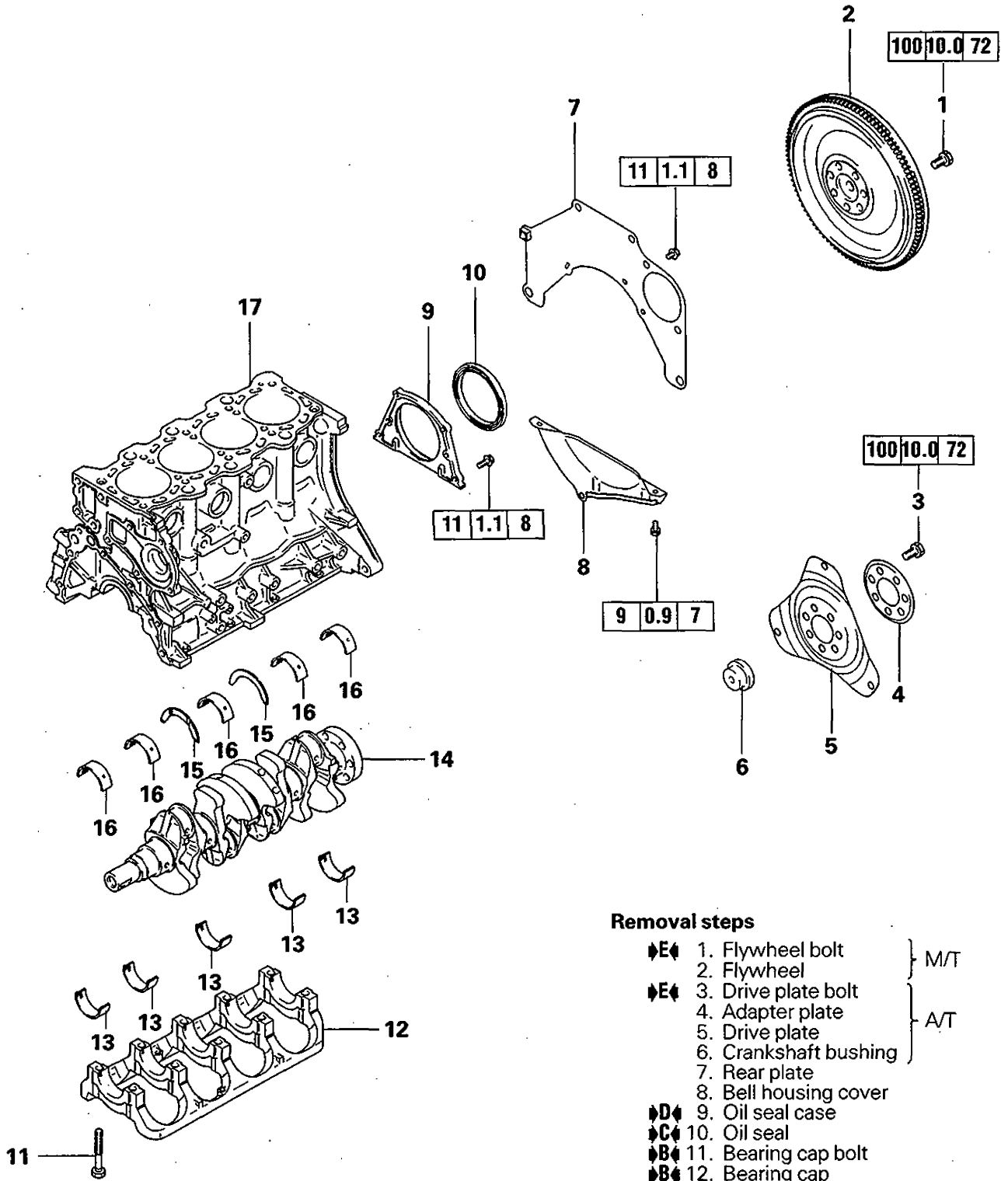

**Removal steps**

- ◆E◆ 1. Flywheel bolt
- 2. Flywheel
- ◆E◆ 3. Drive plate bolt
- 4. Adapter plate
- 5. Drive plate
- 6. Crankshaft bushing
- 7. Rear plate
- 8. Bell housing cover
- ◆D◆ 9. Oil seal case
- ◆C◆ 10. Oil seal
- ◆B◆ 11. Bearing cap bolt
- ◆B◆ 12. Bearing cap
- ◆A◆ 13. Crankshaft bearing, lower
- 14. Crankshaft
- ◆A◆ 15. Thrust bearing
- ◆A◆ 16. Crankshaft bearing, upper
- 17. Cylinder block

M/T  
A/T



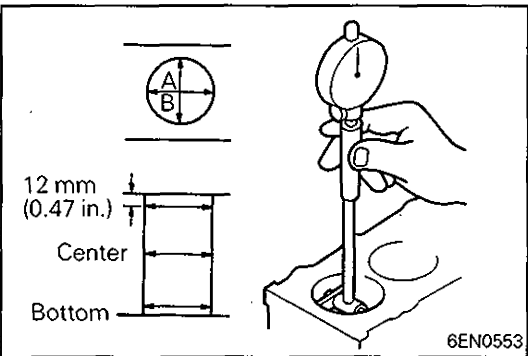
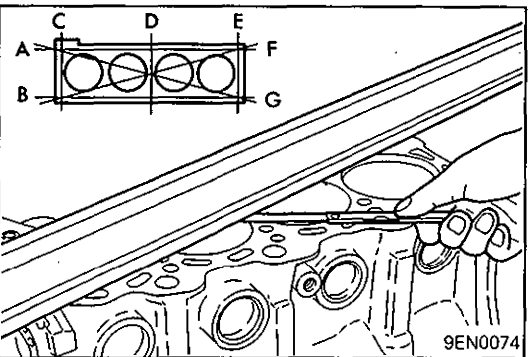
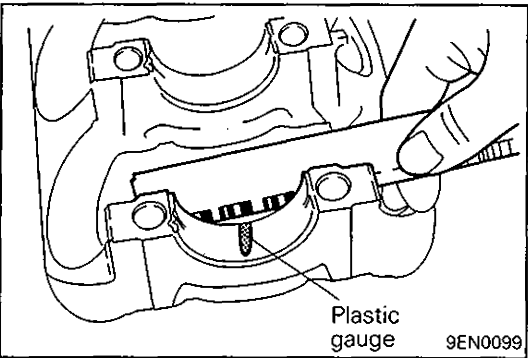
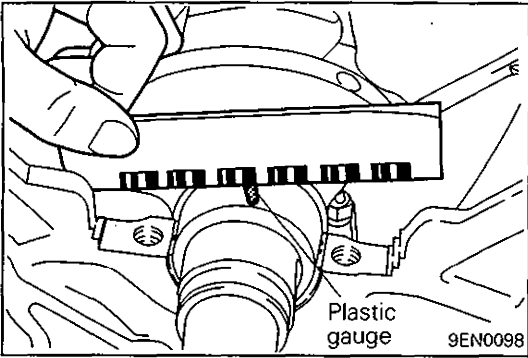

**INSPECTION**

**CRANKSHAFT OIL CLEARANCE (PLASTIC GAUGE METHOD)**

- (1) Remove oil from crankshaft journal and crankshaft bearing.
- (2) Install the crankshaft.
- (3) Cut the plastic gauge to the same length as the width of bearing and place it on journal in parallel with its axis.

- (4) Install the crankshaft bearing cap carefully and tighten the bolts to specified torque.
- (5) Carefully remove the crankshaft bearing cap.
- (6) Measure the width of the plastic gauge at its widest part by using a scale printed on the plastic gauge package.

**Standard value: 0.02 – 0.04 mm (0.0008 – 0.0016 in.)**  
**Limit: 0.1 mm (0.0040 in.)**

**CYLINDER BLOCK**

- (1) Using a straightedge and feeler gauge, check the block top surface for warpage. Make sure that the surface is free from gasket chips and other foreign matter.

**Standard value: 0.05 mm (0.0020 in.) or less**  
**Limit: 0.1 mm (0.0040 in.)**

- (2) If the distortion is excessive, correct within the allowable limit or replace.

**Grinding limit: 0.2 mm (0.008 in.)**

**The total thickness of the stock allowed to be removed from cylinder block and mating cylinder head is 0.2 mm (0.008 in.) at maximum.**

**Cylinder block height (when new):**

243.5 mm (9.59 in.)	.....	4G91, 4G92
263.5 mm (10.37 in.)	.....	4G93

- (3) Check cylinder walls for scratches and seizure. If defects are evident, correct (bored to oversize) or replace.
- (4) Using cylinder gauge, measure the cylinder bore and cylindricity. If worn badly, correct cylinder to an oversize and replace piston and piston rings. Measure at the points shown in illustration.

**Standard value:**

**Cylinder I.D.:**

78.40 – 78.43 mm (3.0866 – 3.0878 in.)	.....	4G91
81.00 – 81.03 mm (3.1890 – 3.1902 in.)	.....	4G92, 4G93

**Out-of-roundness and taper of cylinder bore:**  
**0.01 mm (0.0004 in.) or less**

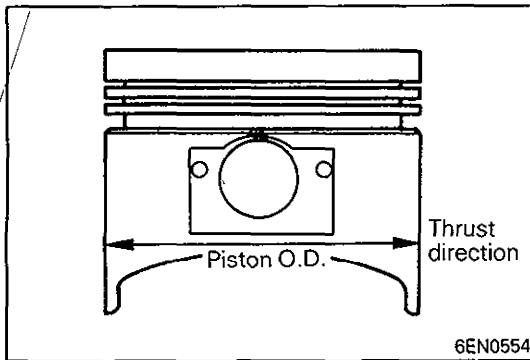
**BORING CYLINDER**

- (1) Oversize pistons to be used should be determined on the basis of the largest bore cylinder.

**Piston size identification**

Size	Identification mark
0.25 mm (0.01 in.) O.S.	0.25
0.50 mm (0.02 in.) O.S.	0.50
0.75 mm (0.03 in.) O.S.	0.75
1.00 mm (0.04 in.) O.S.	1.00

**NOTE**

Size mark is stamped on piston top.

- (2) Measure outside diameter of piston to be used. Measure it in thrust direction as shown.
- (3) Based on measured piston O.D. calculate boring finish dimension.

**Boring finish dimension = Piston O.D. + (Clearance between piston O.D. and cylinder) – 0.02 mm (0.0008 in.) (honing margin)**

- (4) Bore all cylinders to calculated boring finish dimension.

**Caution**

- **To prevent distortion that may result from temperature rise during honing, bore cylinders, working from No. 2 to No. 4 to No. 1 to No. 3.**
- (5) Hone to final finish dimension (piston O.D. + clearance between piston O.D. and cylinder.)
- (6) Check clearance between piston and cylinder.

**Clearance between piston and cylinder:****Engine without turbocharger**

**0.02 – 0.04 mm (0.0008 – 0.0016 in.)**

**Engine with turbocharger**

**0.03 – 0.05 mm (0.0012 – 0.0020 in.)**

**NOTE**

When boring cylinders, finish all of four cylinders to same oversize. Do not bore only one cylinder to an oversize.

**SERVICE POINTS OF REASSEMBLY**

**◆◆ INSTALLATION OF CRANKSHAFT BEARING**

(1) When the bearings are to be replaced, select correct ones and install them in the correct positions according to the identification marks stamped on the crankshaft and the top surface of the cylinder block.

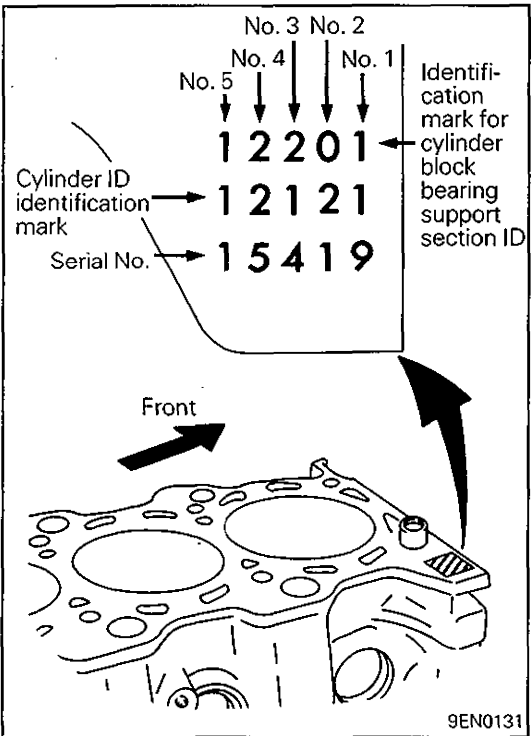
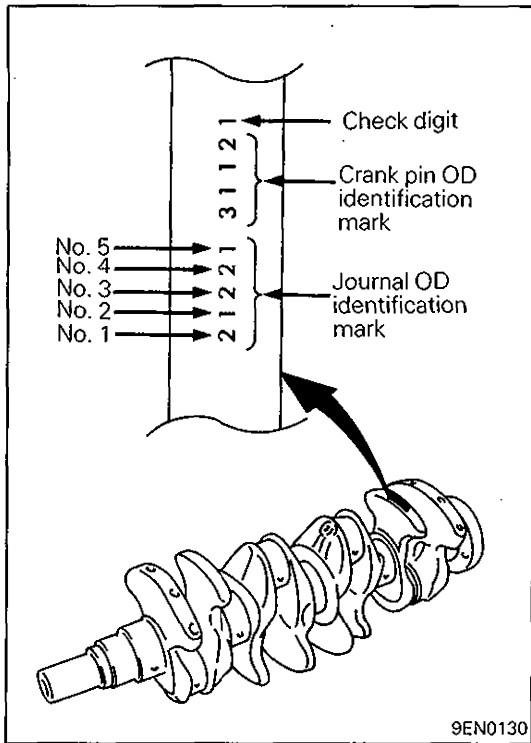

Crankshaft journal		Cylinder block bearing bore		Crankshaft bearing		
Identification mark	O.D. mm (in.)	Identification mark	I.D. mm (in.)	Identification mark (service parts)	Identification color (Line production parts)	Thickness mm (in.)
1	49.994 - 50.000 (1.9683 - 1.9685)	0	54.000 - 54.006 (2.1260 - 2.1262)	1	Brown	1.988 - 1.991 (0.0783 - 0.0784)
		1	54.006 - 54.012 (2.1262 - 2.1265)	2	Black	1.991 - 1.994 (0.0784 - 0.0785)
		2	54.012 - 54.018 (2.1265 - 2.1267)	3	Green	1.994 - 1.997 (0.0785 - 0.0786)
2	49.988 - 49.994 (1.9680 - 1.9683)	0	54.000 - 54.006 (2.1260 - 2.1262)	2	Black	1.997 - 2.000 (0.0786 - 0.0787)
		1	54.006 - 54.012 (2.1262 - 2.1265)	3	Green	1.994 - 1.997 (0.0785 - 0.0786)
		2	54.012 - 54.018 (2.1265 - 2.1267)	4	Yellow	1.997 - 2.000 (0.0786 - 0.0787)
3	49.982 - 49.988 (1.9678 - 1.9680)	0	54.000 - 54.006 (2.1260 - 2.1262)	3	Green	2.000 - 2.003 (0.0787 - 0.0789)
		1	54.006 - 54.012 (2.1262 - 2.1265)	4	Yellow	1.997 - 2.000 (0.0786 - 0.0787)
		2	54.012 - 54.018 (2.1265 - 2.1267)	5	Pink*	2.000 - 2.003 (0.0787 - 0.0789)

\* Older bearings may be marked in red.

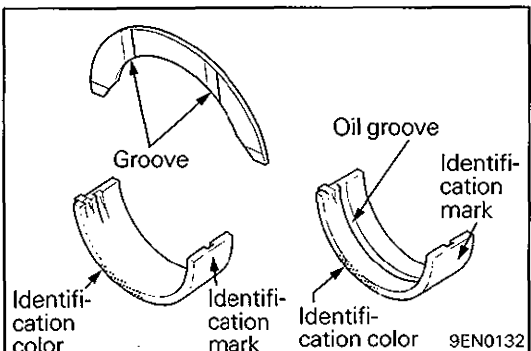

- (2) Install the bearings having an oil groove to the cylinder block.
- (3) Install the bearings having no oil groove to the bearing caps.
- (4) Install the thrust bearings at the No. 3 upper bearing with the grooved side toward the crank web.

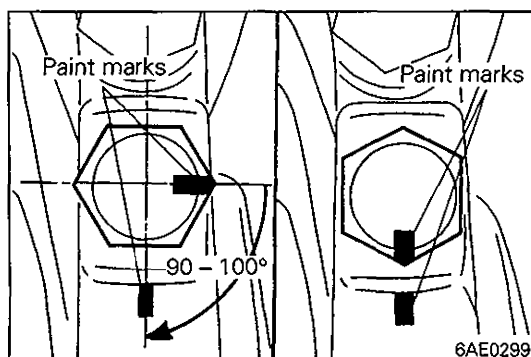
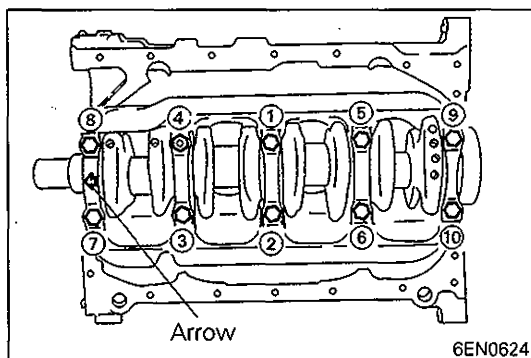
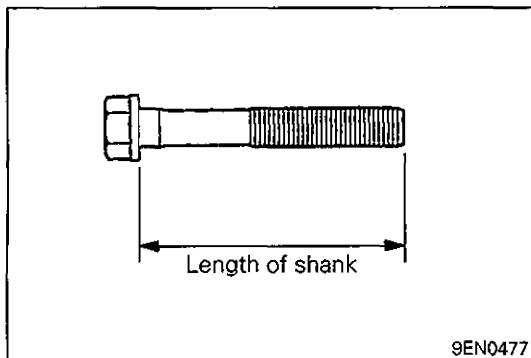

## INSTALLATION OF BEARING CAP / BEARING CAP BOLT

- (1) Install the bearing caps so that their arrows are positioned on the timing belt side.
- (2) When installing the bearing cap bolts, check that the shank length of each bolt meets the limit. If the limit is exceeded, replace the bolt.

**Limit: max. 71.1 mm (2.79 in.)**

- (3) Apply engine oil to the threaded portion and bearing surface of the bolt.
- (4) Tighten the bearing cap bolts to 25 Nm (2.5 kgm, 18 ft.lbs.) torque in the tightening sequence.

- (5) Make a paint mark on the head of each bolt.
- (6) Make a paint mark on the area around the bolt bearing surface at location 90° to 100° in the direction of tightening the bolt, as referenced from the paint mark on the bolt head.
- (7) Give a 90° to 100° turn to the bolts in the tightening sequence. Make sure that the paint mark on the bolt and that on the area around the bolt bearing surface are in alignment.

### Caution

- If the bolt is turned less than 90°, proper fastening performance may not be expected. When tightening the bolt, therefore, be careful to give a sufficient turn to it.
- If the bolt is overtightened (exceeding 100°), loosen the bolt completely and then retighten it by repeating the tightening procedure from step (1).

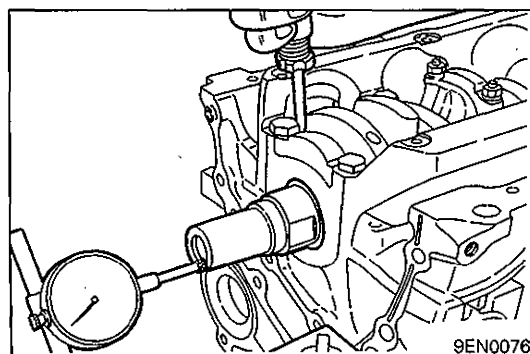

- (8) After installing the bearing caps, make sure that the crankshaft turns smoothly and the end play is correct. If the end play exceeds the limit, replace crankshaft bearings.

**Standard value: 0.05 – 0.25 mm (0.0020 – 0.0098 in.)**

**Limit: 0.4 mm (0.016 in.)**

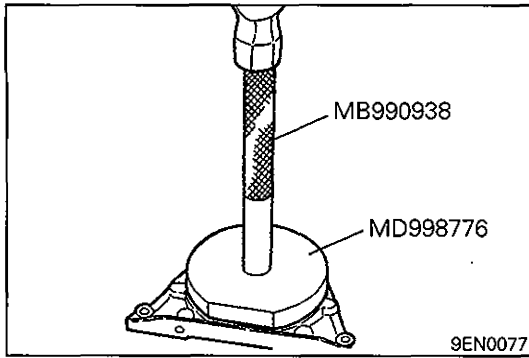

### ◆C◆ INSTALLATION OF OIL SEAL

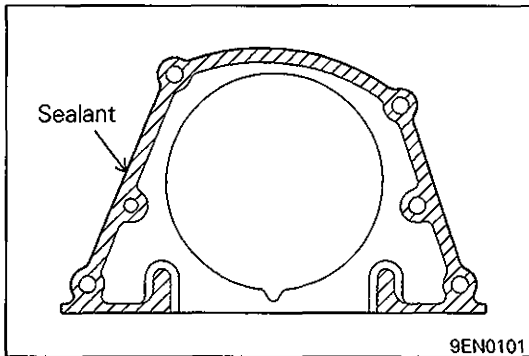

### ◆D◆ APPLICATION OF OIL SEAL CASE

**Specified sealant:**  
**Mitsubishi Genuine Part No. MD970389 or equivalent**

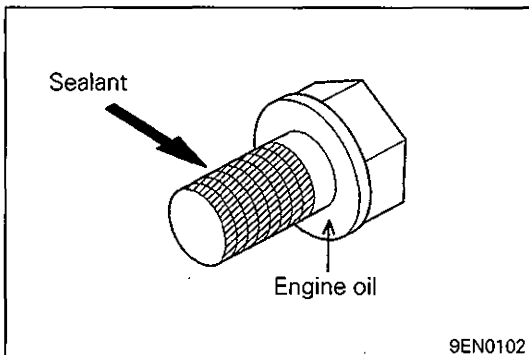

### ◆E◆ INSTALLATION OF DRIVE PLATE BOLT / FLYWHEEL BOLT

- (1) Remove all the remaining sealant from bolts and thread holes of crankshaft.
- (2) Apply engine oil to the flange of bolt.
- (3) Apply engine oil into the thread holes of crankshaft.
- (4) Apply specified sealant to the thread of bolts.

**Specified sealant:**  
**3M Nut Locking Part No. 4171 or equivalent**

- (5) Tighten the bolts to specified torque.

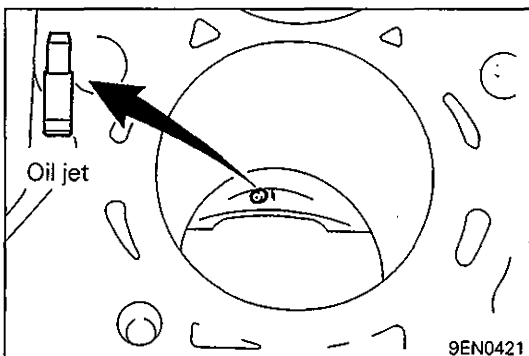

### OIL JET REPLACEMENT

- (1) Using a metal rod with sufficient length, drive out the oil jets.

#### Caution

- Take care not to scratch the cylinder wall.
- Never reuse the removed oil jets.

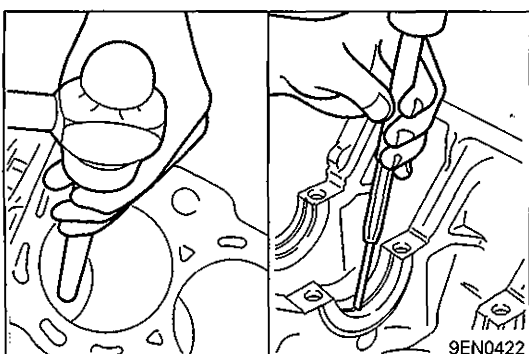

- (2) Using a pin punch [4 – 5 mm (0.16 – 0.20 in.) in diameter], drive in the oil jets until they seat to the bottom.

---

# Service Bulletins

Click on the applicable bookmark to select the Service Bulletin.

---



# SERVICE BULLETIN

QUALITY INFORMATION ANALYSIS  
OVERSEAS SERVICE DEPT. MITSUBISHI MOTORS CORPORATION

<b>SERVICE BULLETIN</b>		No.: MSB-99E11-001																			
		Date: 1999-12-15	<table border="1"> <thead> <tr> <th>&lt;Model&gt;</th> <th>&lt;M/Y&gt;</th> </tr> </thead> <tbody> <tr> <td>(EC) COLT (CJ,CK)</td> <td>96-10</td> </tr> <tr> <td>(EC) LANCER (CJ,CK)</td> <td>96-10</td> </tr> <tr> <td>(EC) SPACE STAR</td> <td>96-10</td> </tr> <tr> <td>(DG1A, DG5A)</td> <td>96-10</td> </tr> <tr> <td>(EC) CARISMA</td> <td>96-10</td> </tr> <tr> <td>(EC) SPACE RUNNER</td> <td>96-10</td> </tr> <tr> <td>(N60,N90)</td> <td></td> </tr> <tr> <td>(EC) PAJERO iO (H6, H7)</td> <td></td> </tr> </tbody> </table>	<Model>	<M/Y>	(EC) COLT (CJ,CK)	96-10	(EC) LANCER (CJ,CK)	96-10	(EC) SPACE STAR	96-10	(DG1A, DG5A)	96-10	(EC) CARISMA	96-10	(EC) SPACE RUNNER	96-10	(N60,N90)		(EC) PAJERO iO (H6, H7)	
<Model>	<M/Y>																				
(EC) COLT (CJ,CK)	96-10																				
(EC) LANCER (CJ,CK)	96-10																				
(EC) SPACE STAR	96-10																				
(DG1A, DG5A)	96-10																				
(EC) CARISMA	96-10																				
(EC) SPACE RUNNER	96-10																				
(N60,N90)																					
(EC) PAJERO iO (H6, H7)																					
<b>Subject:</b> CHANGE IN POSITIONS OF CRANKSHAFT IDENTIFICATION MARKS																					
<b>Group:</b> ENGINE	<b>Draft No.:</b> 99EN531509																				
<b>INFORMATION</b>	INTERNATIONAL CAR ADMINISTRATION OFFICE	 T.NITTA - PROJECT LEADER AFTER SALES SERVICE & CS PROMOTION																			

### 1. Description:

This Service Bulletin informs you that the journal O.D. identification marks and the pin O.D. identification marks have been changed in their positions.

### 2. Applicable Manuals:

Manual	Pub. No.	Language	Page(s)
'98 4G9 Series (E-W) Engine Supplement	PWEE9502-E	(English)	11A-12-2
	PWES9503-E	(Spanish)	
	PWEF9504-E	(French)	
	PWEG9505-E	(German)	
	PWED9506-E	(Dutch)	
	PWEW9507-E	(Swedish)	
'96 4G9 Series Engine Supplement	PWEE9101-E	(English)	11A-18-6
	PWES9102-E	(Spanish)	
	PWEF9103-E	(French)	
	PWEG9104-E	(German)	
	PWED9105-E	(Dutch)	
	PWEW9106-E	(Swedish)	

### 3. Effective Date:

From September 1997  
Effective model: 4G93-G-10Z3K (HP9123)

---

- Crankshaft weight

